



Conduit® AP

MTCAP3 Hardware Guide for Australia and New Zealand



Conduit AP MTCAP3 Hardware Guide for Australia and New Zealand

Models: MTCAP3-EN-A23UEA-LWM, MTCAP3-EN-A23UEA-DWM

Part Number: S000802, Version 1.0

Copyright

This publication may not be reproduced, in whole or in part, without the specific and express prior written permission signed by an executive officer of Multi-Tech Systems, Inc. All rights reserved. **Copyright © 2023 by Multi-Tech Systems, Inc.**

Multi-Tech Systems, Inc. makes no representations or warranties, whether express, implied or by estoppels, with respect to the content, information, material and recommendations herein and specifically disclaims any implied warranties of merchantability, fitness for any particular purpose and non-infringement.

Multi-Tech Systems, Inc. reserves the right to revise this publication and to make changes from time to time in the content hereof without obligation of Multi-Tech Systems, Inc. to notify any person or organization of such revisions or changes.

Trademarks and Registered Trademarks

MultiTech, the MultiTech logo, DeviceHQ, and MultiConnect and Conduit are registered trademarks and mPower is trademarks of Multi-Tech Systems, Inc. All other products and technologies are the trademarks or registered trademarks of their respective holders.

Legal Notices

The MultiTech products are not designed, manufactured or intended for use, and should not be used, or sold or re-sold for use, in connection with applications requiring fail-safe performance or in applications where the failure of the products would reasonably be expected to result in personal injury or death, significant property damage, or serious physical or environmental damage. Examples of such use include life support machines or other life preserving medical devices or systems, air traffic control or aircraft navigation or communications systems, control equipment for nuclear facilities, or missile, nuclear, biological or chemical weapons or other military applications (“Restricted Applications”). Use of the products in such Restricted Applications is at the user’s sole risk and liability.

The MultiTech products and the final application of the MultiTech products should be thoroughly tested to ensure the functionality of the MultiTech products as used in the final application. The designer, manufacturer and reseller has the sole responsibility of ensuring that any end user product into which the MultiTech product is integrated operates as intended and meets its requirements or the requirements of its direct or indirect customers. MultiTech has no responsibility whatsoever for the integration, configuration, testing, validation, verification, installation, upgrade, support or maintenance of such end user product, or for any liabilities, damages, costs or expenses associated therewith, except to the extent agreed upon in a signed written document. To the extent MultiTech provides any comments or suggested changes related to the application of its products, such comments or suggested changes is performed only as a courtesy and without any representation or warranty whatsoever.

Contacting MultiTech

Sales	Support
sales@multitech.com	support@multitech.com
+1 (763) 785-3500	+1 (763) 717-5863

Website

<https://www.multitech.com>

Knowledge Base

For immediate access to support information and resolutions for MultiTech products, visit <https://www.multitech.com/kb.go>.

Support Portal

To create an account and submit a support case directly to our technical support team, visit: <https://support.multitech.com>.

Warranty

To read the warranty statement for your product, visit <https://www.multitech.com/legal/warranty>.

World Headquarters

Multi-Tech Systems, Inc.
2205 Woodale Drive, Mounds View, MN 55112
USA

Contents

Chapter 1 – Product Overview	5
Overview	5
Package Contents	5
Product Build Options	6
Documentation Overview	6
Related Documentation	6
Chapter 2 – Specifications and Hardware Information	7
Dimensions	7
Specifications for 915 MHz Models	8
Connectors and LEDs	8
AC Power Consumption	10
LoRa Power	10
LoRa Maximum Output Power	10
Resetting the Device	11
Antenna	12
LoRa Antenna	12
Chapter 3 – Safety Information	13
Power Supply Caution	13
Ethernet Ports	13
Ports Ethernet	13
General Safety	13
Radio Frequency (RF) Safety	13
Sécurité relative aux appareils à radiofréquence (RF)	14
Interference with Pacemakers and Other Medical Devices	14
Potential interference	14
Precautions for pacemaker wearers	14
Device Maintenance	15
UL Notice	15
Spécifications UL	15
User Responsibility	15
Chapter 4 – Labels	16
Example Device Labels	16
MTCAP3-EN Models	16
Chapter 5 – Setting Up Hardware	17
Attaching the Antenna	17
Cabling the Device	17

Chapter 6 – Getting Started	18
Setting Up Your Credentials (Commissioning) for mPower	18
mPower Models First-Time Setup	18
Connecting with LoRaWAN End Devices.....	18
Chapter 7 – Mounting the Device.....	19
Mounting the Device.....	19
You will need.....	19
Determining Location.....	19
Mounting the Device	19
Chapter 8 – Regulatory Information.....	22
Waste Electrical and Electronic Equipment Statement	22
WEEE Directive.....	22
Instructions for Disposal of WEEE by Users in the European Union	22
REACH-SVHC Statement	22
Registration of Substances.....	22
Restriction of the Use of Hazardous Substances (RoHS)	23
Index.....	24

Chapter 1 – Product Overview

Overview

Conduit AP (MTCAP3) connects thousands of IoT assets to the cloud using the LoRaWAN[®] protocol. It expands LoRa network coverage to difficult to reach areas and is capable of packet forwarding user data between LoRa end devices and a centrally located network server on the cloud, in a data center, or a public network.

Note: Check for an updated version of this document at <https://www.multitech.com/brands/multiconnect-conduit-ap>.

Package Contents

For models with all internal antennas

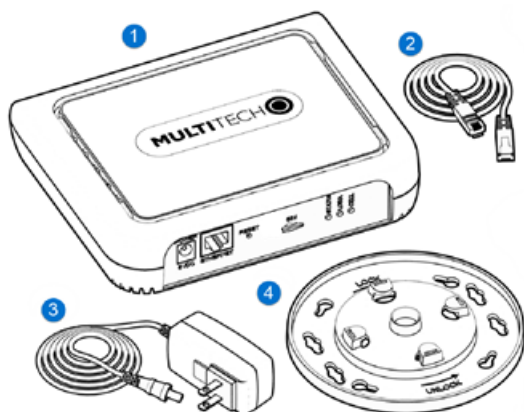

For models with an external LoRa antenna.

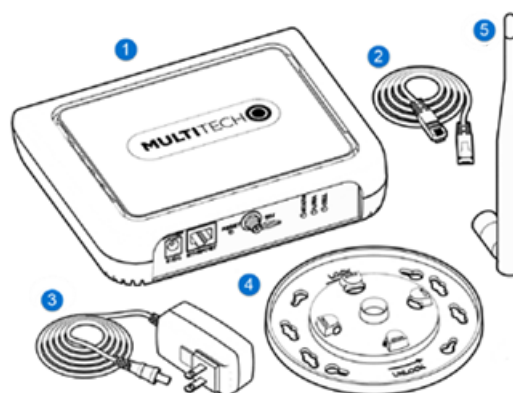

Your device ships with the following:

#	Description	Quantity
1	Conduit AP Access Point	1
2	RJ45 Ethernet cable	1
3	5 Volt, 2.5 Amp power supply	1
4	Mounting bracket	1
5	LoRa antenna (models with external antenna only)	1
Not pictured	Mounting feet set	1
	Quick start	1

Important: Contact MultiTech Systems if a replacement power supply is needed. Using a different power supply may damage the device and voids the warranty.

Product Build Options

Product	Description
MTCAP3-EN-A23UEA-LWM	Ethernet-only mPower programmable access point with LoRa 915 MHz and external LoRa antenna
MTCAP3-EN-A23UEA-DWM	Ethernet-only mPower programmable access point with LoRa 915 MHz

Documentation Overview

The following documents are available at <http://www.multitech.com/brands/multiconnect-conduit-ap>. Select your model to find the documents specific for that device.

Document	Description (Part Number)
Conduit AP MTCAP3 Hardware Guide for Australia and New Zealand	This document. Hardware, regulatory, and getting started information. (S000802)
mPower Software Guide	<i>For mPower models only.</i> Includes steps for configuring and using devices using the mPower platform. (S000727)
Conduit AP MTCAP, MTCAP2, and MTCAP3 Quick Start	Steps for getting started with hardware. Ships with the device and is available online.
Application Notes	Application Notes include steps for connecting end points to the device.

Note: Quick Start Guide numbers increase by one when the printed version is updated.

Related Documentation

Our developer site includes advanced mPower and LoRa information.

- For mPower information, go to <http://www.multitech.net/developer/software/aep/>
- For LoRa information, <http://www.multitech.net/developer/software/lora/>

Chapter 2 – Specifications and Hardware Information

Dimensions

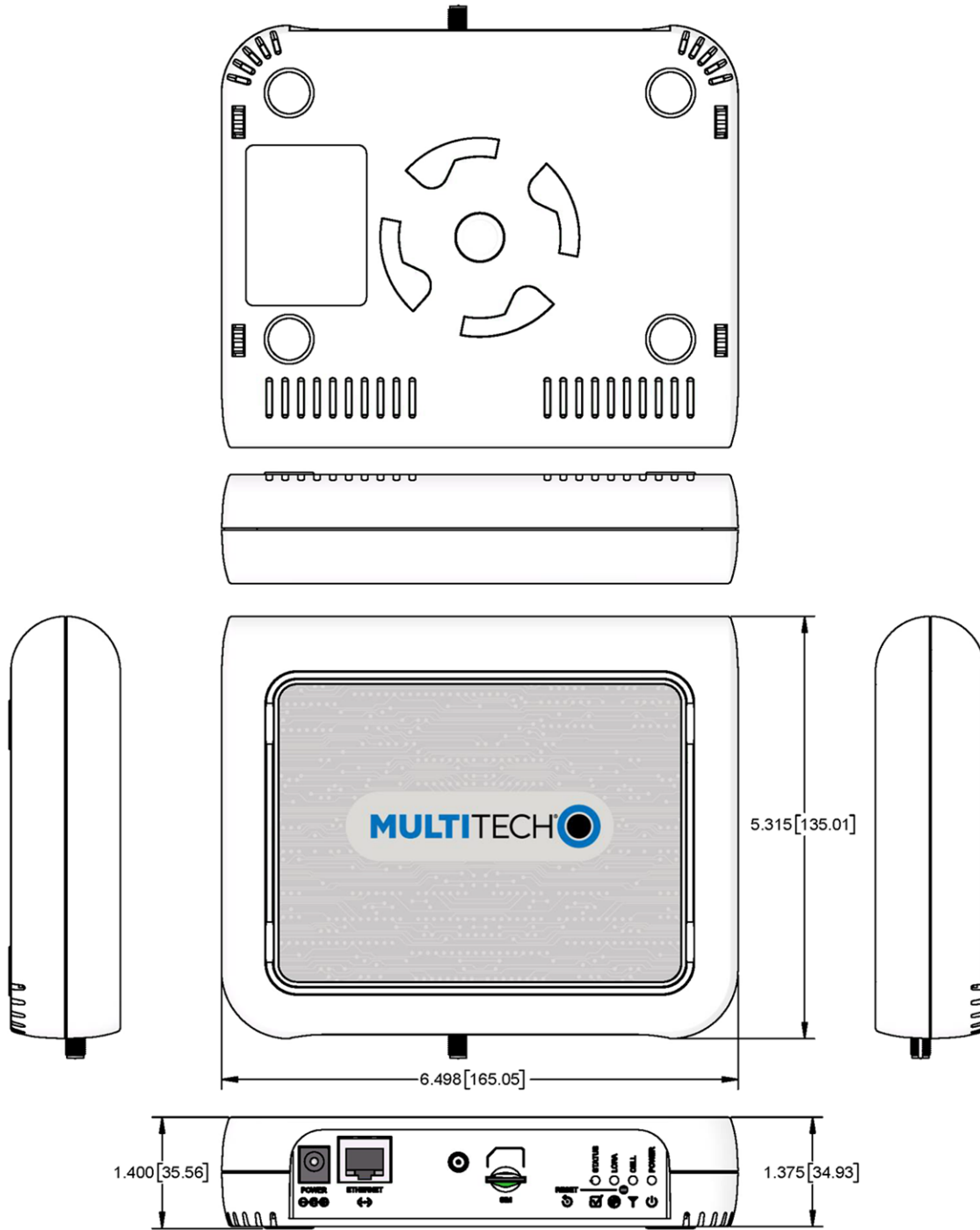

DIMENSIONS IN In [mm]

Specifications for 915 MHz Models

Category	Description
General	
Standards	LoRaWAN 1.0.2 specifications
Radio Frequency	
ISM Band	915 MHz ISM band
Physical Description	
Weight	0.41 kg
Dimensions	Refer to Mechanical Drawings for Dimensions.
Chassis Type	PC-ABS
Environment	
Operating Temperature ¹	0° C to +70° C
Storage Temperature	-40° C to +85° C
Humidity	20%-90% RH, non-condensing
Power Requirements	
Operating Voltage	5Vdc
Certifications and Compliance	
EMC and Radio Compliance	RSS210 (LoRa)
Safety Compliance	IEC 62368-1

¹ UL listed at 40° C, limited by AC power supply. Product has been tested to +70° C excluding power supply.

Connectors and LEDs

LoRa only models

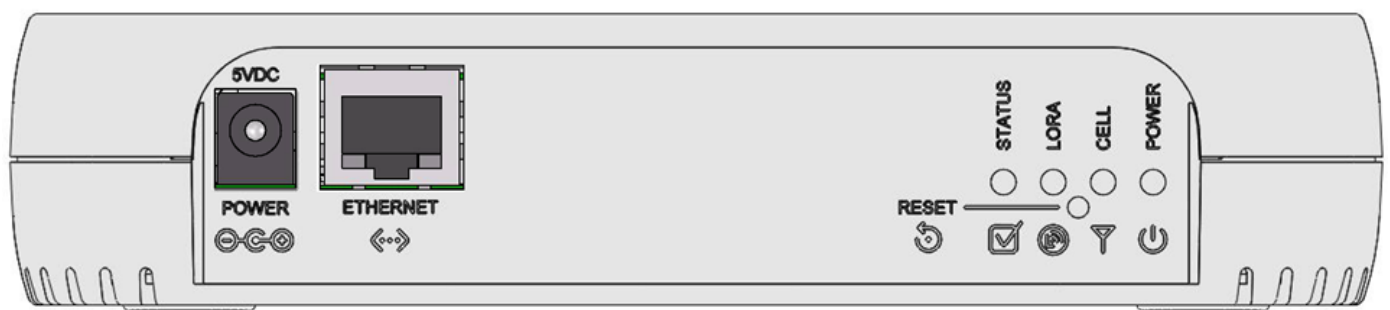

LoRa only models with external LoRa antenna

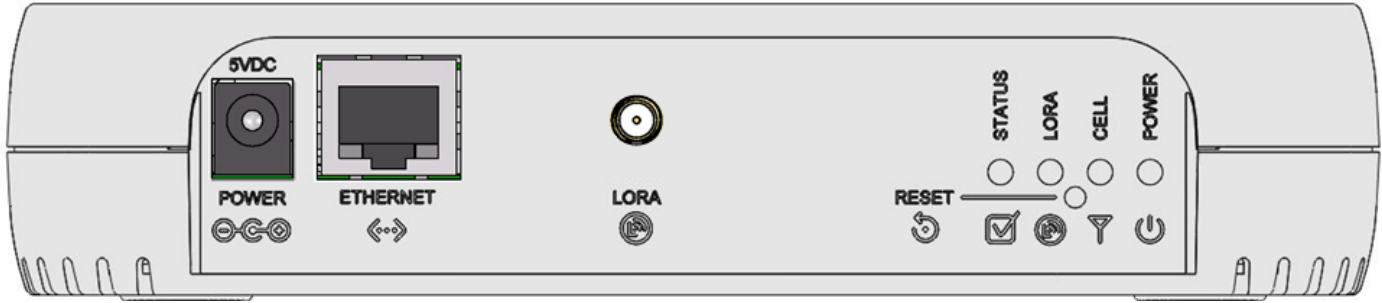

Note: Some features are available only on select models.

Item	Description
Connectors	
Power	5 Volt power jack.
Ethernet	RJ45 Ethernet jack.
Reset	Reset button. Reboots device or restores factory defaults. Refer to Resetting the Device for details.
LORA	RP-SMA connector for external LoRa antenna. <i>(Select models)</i>
SIM	<i>Cellular models only.</i> Micro (3FF) SIM slot. Refer to Installing SIM Card for details.
LEDs	
STATUS	On (Solid): Firmware is booting.
	Flashing: Blinks when operating system is fully loaded.
	Off: If this LED remains off one minute after power is applied, troubleshoot the device.
LORA	On: Lights when LoRa software is active.
	Flashing: Firmware upgrade mode.
	Off: LoRa services stopped.
CELL	<i>Cellular models only.</i>
Power	On: Powered up, normal operation.
	Slow Flashing: Firmware upgrade mode.
	Off: No power, either device disconnected from power or powered off.
Ethernet Link	Left LED on the Ethernet connector. Blinks when data is sent or received on the Ethernet link. Steady light when there is a valid Ethernet connection.
Ethernet Speed	Right LED on the Ethernet connector. Lit when the Ethernet is linked at 100 Mbps. If not lit, the Ethernet is linked at 10 Mbps.

AC Power Consumption

- Ethernet active, LoRa RX: 2W

LoRa Power

LoRa Maximum Output Power

Australia

- **Maximum EIRP** (includes external LoRa antenna): 27.5 dBm

New Zealand

- **Maximum EIRP** (includes external LoRa antenna): 24.7 dBm

Resetting the Device

You need:

- A pin, paperclip, or similar thin object that can fit into the reset hole

To reset the device:

1. Find the hole labeled RESET. The reset button is recessed into the case.
2. Use the pin to press and release the RESET button as follows:

Reset options:

- To reboot, press RESET for less than 3 seconds.
- To reboot and restore user-defined defaults (if previously set), press RESET for 3 to 29 seconds.
- To reboot, restore factory settings, and erase user-defined defaults, press RESET for 30 seconds or longer.

The device restarts in commissioning mode. The system automatically removes all user accounts.

For mPower devices, enter a new username and password to create your new administrative account. (Refer to **User Accounts** in the appropriate software guide for details on username and password requirements.)

Note: The device reboots when restoring settings.

For more information about commissioning mode, consult the mPower Software Guide. Refer to [Documentation Overview](#) for details.

Antenna

Your device ships with the following antenna. Contact MultiTech if you need a replacement antenna.

LoRa Antenna

Manufacturer:	PulseLarsen Antenna
Description:	868-928 MHz RP-SMA Antenna, 8"
Model Number:	W1063

MultiTech ordering information:

Ordering Part Number	Quantity
AN868-915A-1HRA	1
AN868-915A-10HRA	10
AN868-915A-50HRA	50

LoRa Antenna Specifications

Category	Description
Frequency Range	868-928 MHz
Impedance	50 Ohms
VSWR	≤ 2.0
Gain	1.0 dBi
Radiation	Omni
Polarization	Vertical

Chapter 3 – Safety Information

Power Supply Caution

CAUTION: Do not replace the power supply with one designed for another product; doing so can damage the modem and void your warranty. Adapter shall be installed near the equipment and shall be easily accessible.

CAUTION: Pour garantir une protection continue contre les risques d'incendie, remplacez les fusibles uniquement par des fusibles du même type et du même calibre. L'adaptateur doit être installé à proximité de l'appareil et doit être facilement accessible.

Ethernet Ports

CAUTION: Ethernet ports and command ports are not designed to be connected to a public telecommunication network or used outside the building.

Ports Ethernet

CAUTION: Les ports Ethernet et de commande ne sont pas conçus pour être raccordés à un réseau de télécommunications public ou utilisé à l'extérieur du bâtiment.

General Safety

The device is designed for and intended to be used in fixed and mobile applications. Fixed means the device is physically secured at one location and cannot be easily moved to another location. Mobile means the device is used in other than fixed locations.

CAUTION: Maintain a separation distance of at least 20 cm (8 inches) between the transmitter's antenna and the body of the user or nearby persons. The device is not designed for or intended to be used in portable applications within 20 cm (8 inches) of the user's body.

Attention: Maintenir une distance d'au moins 20 cm (8 po) entre l'antenne du récepteur et le corps de l'utilisateur ou à proximité de personnes. Le modem n'est pas conçu pour, ou destinés à être utilisés dans les applications portables, moins de 20 cm du corps de l'utilisateur.

Radio Frequency (RF) Safety

Due to the possibility of radio frequency (RF) interference, it is important that you follow any special regulations regarding the use of radio equipment. Follow the safety advice given below.

- Operating your device close to other electronic equipment may cause interference if the equipment is inadequately protected. Observe any warning signs and manufacturers' recommendations.
- Different industries and businesses restrict the use of devices. Respect restrictions on the use of radio equipment in fuel depots, chemical plants, or where blasting operations are in process. Follow restrictions for any environment where you operate the device.
- Do not place the antenna outdoors.
- Switch OFF your wireless device when in an aircraft. Using portable electronic devices in an aircraft may endanger aircraft operation, disrupt the network, and is illegal. Failing to observe this restriction may lead to suspension or denial of services to the offender, legal action, or both.
- Switch OFF your wireless device when around gasoline or diesel-fuel pumps and before filling your vehicle with fuel.

- Switch OFF your wireless device in hospitals and any other place where medical equipment may be in use.

Sécurité relative aux appareils à radiofréquence (RF)

À cause du risque d'interférences de radiofréquence (RF), il est important de respecter toutes les réglementations spéciales relatives aux équipements radio. Suivez les conseils de sécurité ci-dessous.

- Utiliser l'appareil à proximité d'autres équipements électroniques peut causer des interférences si les équipements ne sont pas bien protégés. Respectez tous les panneaux d'avertissement et les recommandations du fabricant.
- Certains secteurs industriels et certaines entreprises limitent l'utilisation des appareils. Respectez ces restrictions relatives aux équipements radio dans les dépôts de carburant, dans les usines de produits chimiques, ou dans les zones où des dynamitages sont en cours. Suivez les restrictions relatives à chaque type d'environnement où vous utiliserez l'appareil.
- Ne placez pas l'antenne en extérieur.
- Éteignez votre appareil sans fil dans les avions. L'utilisation d'appareils électroniques portables en avion est illégale: elle peut fortement perturber le fonctionnement de l'appareil et désactiver le réseau. S'il ne respecte pas cette consigne, le responsable peut voir son accès aux services suspendu ou interdit, peut être poursuivi en justice, ou les deux.
- Éteignez votre appareil sans fil à proximité des pompes à essence ou de diesel avant de remplir le réservoir de votre véhicule de carburant.
- Éteignez votre appareil sans fil dans les hôpitaux ou dans toutes les zones où des appareils médicaux sont susceptibles d'être utilisés.

Interference with Pacemakers and Other Medical Devices

Potential interference

Radio frequency energy (RF) from devices can interact with some electronic devices. This is electromagnetic interference (EMI). The FDA helped develop a detailed test method to measure EMI of implanted cardiac pacemakers and defibrillators from devices. This test method is part of the Association for the Advancement of Medical Instrumentation (AAMI) standard. This standard allows manufacturers to ensure that cardiac pacemakers and defibrillators are safe from device EMI.

Precautions for pacemaker wearers

If EMI occurs, it could affect a pacemaker in one of three ways:

- Stop the pacemaker from delivering the stimulating pulses that regulate the heart's rhythm.
- Cause the pacemaker to deliver the pulses irregularly.
- Cause the pacemaker to ignore the heart's own rhythm and deliver pulses at a fixed rate.

Based on current research, devices do not pose a significant health problem for most pacemaker wearers. However, people with pacemakers may want to take simple precautions to be sure that their device doesn't cause a problem.

- Keep the device on the opposite side of the body from the pacemaker to add extra distance between the pacemaker and the device.
- Avoid placing a turned-on device next to the pacemaker (for example, don't carry the device in a shirt or jacket pocket directly over the pacemaker).

Device Maintenance

Do not attempt to disassemble the device. There are no user serviceable parts inside.

When maintaining your device:

- Do not misuse the device. Follow instructions on proper operation and only use as intended. Misuse could make the device inoperable, damage the device and/or other equipment, or harm users.
- Do not apply excessive pressure or place unnecessary weight on the device. This could result in damage to the device or harm to users.
- Do not use this device in explosive or hazardous environments unless the model is specifically approved for such use. The device may cause sparks. Sparks in explosive areas could cause explosion or fire and may result in property damage, severe injury, and/or death.
- Do not expose your device to any extreme environment where the temperature or humidity is high. Such exposure could result in damage to the device or fire. Refer to the device specifications regarding recommended operating temperature and humidity.
- Do not expose the device to water, rain, or spilled beverages. It is not waterproof. Exposure to liquids could result in damage to the device.
- Using accessories, such as antennas, that MultiTech has not authorized or that are not compliant with the device's accessory specifications may invalidate the warranty.

If the device is not working properly, contact MultiTech Technical Support.

UL Notice

UL Listed at 40° C, limited by power supply. UL Certification does not apply or extend to an ambient above 40° C and has not been evaluated by UL for ambient greater than 40° C. "UL has evaluated this device for use in ordinary locations only. Installation in a vehicle or other outdoor locations has not been evaluated by UL. UL Certification does not apply or extend to use in vehicles or outdoor applications or in ambient above 40° C."

Spécifications UL

Listé UL à 40° C, limité par l'alimentation. La certification UL ne s'applique pas ou ne s'étend pas à des températures dépassant 40° C, et le produit n'a pas été évalué par UL pour une température ambiante dépassant 40° C. « UL a évalué cet appareil pour une utilisation en zone ordinaire uniquement. Le produit n'a pas été évalué par UL pour une installation dans un véhicule ou en extérieur. La certification UL ne s'applique pas ou ne s'étend pas aux applications dans un véhicule, en extérieur ou en présence d'une température ambiante supérieure à 40° C ».

User Responsibility

Respect all local regulations for operating your wireless device. Use the security features to block unauthorized use and theft.

Chapter 4 – Labels

Example Device Labels

Note: Actual labels vary depending on the regulatory approval markings and content.

The label shown is not the actual size.

- 1 - MultiTech Model Identification.
- 2 - MultiTech Ordering Part Number.
- 3 - UUID
- 4 - Ethernet MAC Address
- 5 - Device Node Number

MTCAP3-EN Models

Device Label



Package Label

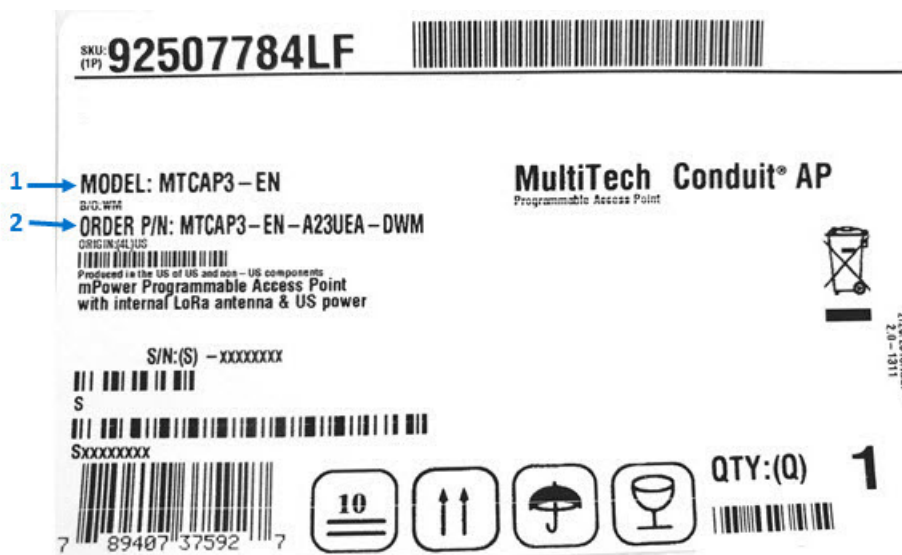

Chapter 5 – Setting Up Hardware

Attaching the Antenna

(Models with external antenna only)

To connect the antenna:

- Finger-tighten the antenna to the antenna connector on your device.

Cabling the Device

To cable the device:

1. For Ethernet only models, connect the Ethernet cable to the Ethernet port on the device and to your computer.
2. Attach the plug for your country to the power supply.
3. Connect the power supply to the device's power jack and plug it into an electrical outlet. When the operating system is fully loaded, the STATUS LED blinks.

Important: The power supply is 5V at the connector. Verify you are connecting the power supply that shipped with the device. Using a power supply with higher voltage damages the device.

Ethernet only models with external LoRa antenna

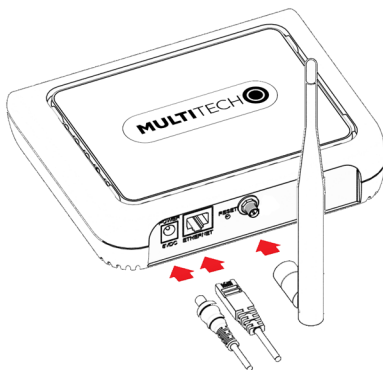

Ethernet only models, all internal antennas



Chapter 6 – Getting Started

Setting Up Your Credentials (Commissioning) for mPower

The first time the device powers up, it goes into commissioning mode. The system requires you to set up an administrative user. To do this:

Note: MultiTech recommends using Firefox.

1. Open a browser on your computer and enter the default IP address in the URL field, **192.168.2.1**. Most browsers display a warning about HTTP addresses being unsafe because of a self-signed certificate.
 - For Edge, click **Advanced** and then click Continue to **192.168.2.1**.
 - For Firefox, click **Advanced** and then click **Accept the Risk and Continue**.
 - **Note:** At the time of publication, the current version of Chrome was not supported.
2. Enter a username for the administrative user. Click **OK**. Follow on screen instructions for usernames.
3. Enter a password and click **OK**. Follow on screen instructions for a secure password.
4. Enter the password again to confirm. Click **OK**.
5. Log into the device using the new username and password.

The First-Time Setup Wizard appears.

mPower Models First-Time Setup

If your device uses the mPower platform, refer to First-Time Setup in [mPower Software Guide \(S000727\)](#) for details. It is available through your model's page at <https://www.multitech.com/brands/multiconnect-conduit-ap>

Connecting with LoRaWAN End Devices

For help connecting your device with LoRaWAN end devices, refer to Application Notes at <https://www.multitech.com/brands/multiconnect-conduit-ap>

Chapter 7 – Mounting the Device

Mounting the Device

The device ships with a mounting bracket.

You will need

- Device
- Mounting bracket
- Four #6 (3.5mm) screws with anchors (not provided)
- Screwdriver
- Drill

Mounting Bracket

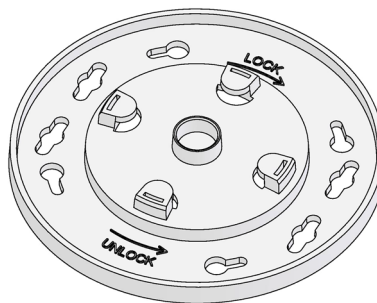

Determining Location

Follow these guidelines for best performance:

- The LoRa antenna is omnidirectional, but for best results, mount the device so the LoRa antenna is in a vertical position as shown in the following image.
- For optimal performance, place the device at a level higher than the end devices.
- Select a location central to all devices to be connected to this device.
- Avoid obstructions.

Important: Thick walls and reflective surfaces, such as metal, weaken the signal between the device and other devices.

- We recommend conducting a site survey to test the signal strength in different locations before you mount the device.

Mounting the Device

1. Determine where you want to mount the device.
2. Mark where you want the screws to go.

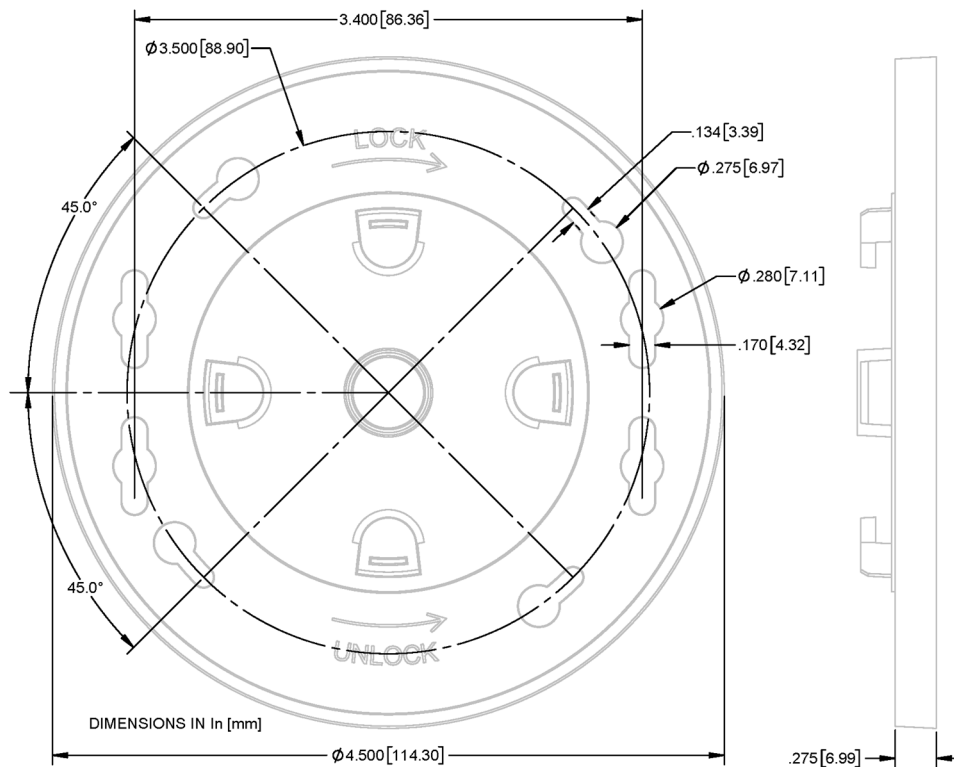

3. Drill holes for the screws and insert anchors.
4. Place the mounting bracket and secure it with screws.
5. Attach the device to the bracket and rotate until it locks into place.



Models with Internal LoRa Antenna Only



Models with External LoRa Antenna



Chapter 8 – Regulatory Information

Waste Electrical and Electronic Equipment Statement

Note: This statement may be used in documentation for your final product applications.

WEEE Directive

The WEEE Directive places an obligation on EU-based manufacturers, distributors, retailers, and importers to take-back electronics products at the end of their useful life. A sister directive, ROHS (Restriction of Hazardous Substances) complements the WEEE Directive by banning the presence of specific hazardous substances in the products at the design phase. The WEEE Directive covers all MultiTech products imported into the EU as of August 13, 2005. EU-based manufacturers, distributors, retailers and importers are obliged to finance the costs of recovery from municipal collection points, reuse, and recycling of specified percentages per the WEEE requirements.

Instructions for Disposal of WEEE by Users in the European Union

The symbol shown below is on the product or on its packaging, which indicates that this product must not be disposed of with other waste. Instead, it is the user's responsibility to dispose of their waste equipment by handing it over to a designated collection point for the recycling of waste electrical and electronic equipment. The separate collection and recycling of your waste equipment at the time of disposal will help to conserve natural resources and ensure that it is recycled in a manner that protects human health and the environment. For more information about where you can drop off your waste equipment for recycling, please contact your local city office, your household waste disposal service or where you purchased the product.

July, 2005



REACH-SVHC Statement

Registration of Substances

Multi-Tech Systems, Inc. confirms that none of its products or packaging contain any of the Substances of Very High Concern (SVHC) on the REACH Candidate List, in a concentration above the 0.1% by weight allowable limit.

For the current REACH-SVHC statement, refer to additional regulatory documents at:

<https://www.multitech.com/support/support>

Refer to the following for the most current candidate list of substances: <https://echa.europa.eu/candidate-list-table>.

Restriction of the Use of Hazardous Substances (RoHS)

Multi-Tech Systems, Inc.

Certificate of Compliance

2015/863

Multi-Tech Systems, Inc. confirms that its embedded products comply with the chemical concentration limitations set forth in the directive 2015/863 of the European Parliament (Restriction of the use of certain Hazardous Substances in electrical and electronic equipment - RoHS 3).

These MultiTech products do not contain the following banned chemicals¹:

- Lead, [Pb] < 1000 PPM
- Mercury, [Hg] < 100 PPM
- Cadmium, [Cd] < 100 PPM
- Hexavalent Chromium, [Cr+6] < 1000 PPM
- Polybrominated Biphenyl, [PBB] < 1000 PPM
- Polybrominated Diphenyl Ethers, [PBDE] < 1000 PPM
- Bis(2-Ethylhexyl) phthalate (DEHP): < 1000 ppm
- Benzyl butyl phthalate (BBP): < 1000 ppm
- Dibutyl phthalate (DBP): < 1000 ppm
- Diisobutyl phthalate (DIBP): < 1000 ppm

Index

A		
AC power consumption.....	10	
antenna	12	
attach	17	
B		
build options	6	
C		
CELL LED	8	
certifications.....	8	
configuring	18	
connectors.....	8	
D		
device		
maintenance	15	
dimensions	7	
documentation.....	6	
E		
Ethernet	8 17	
Ethernet ports	13	
G		
getting started.....	18	
H		
hazardous substances	23	
I		
interférence des radiofréquences.....	14	
L		
labels	16	
LEDs.....	8	
LORA LED.....	8	
LoRa power	10	
M		
maintenance	15	
modem		
safety	13	
mounting device	19	
mPower software.....	18	
P		
package contents	5	
Ports Ethernet.....	13	
power jack.....	8	
power measurements		
LoRa	10	
power supply.....	17	
R		
radio frequency interference.....	13	
receive sensitivity.....	8	
reset button	8	
reset device.....	11	
RoHS.....	23	
S		
safety.....	13	
modem.....	13	
RF interference	13	
specifications.....	8	
STATUS LED	8	
sécurité.....	13	
interférences RF.....	14	
T		
transmission.....	8	
U		
user responsibility.....	15	