

## Dragonfly™

### MTQ-L4G1 Device Guide



## Dragonfly™ Device Guide

Models: MTQ-L4G1-B02

Part Number: S000762 Rev 1.3

### Copyright

This publication may not be reproduced, in whole or in part, without the specific and express prior written permission signed by an executive officer of Multi-Tech Systems, Inc. All rights reserved. **Copyright © 2021 by Multi-Tech Systems, Inc.**

Multi-Tech Systems, Inc. makes no representations or warranties, whether express, implied or by estoppels, with respect to the content, information, material and recommendations herein and specifically disclaims any implied warranties of merchantability, fitness for any particular purpose and non-infringement.

Multi-Tech Systems, Inc. reserves the right to revise this publication and to make changes from time to time in the content hereof without obligation of Multi-Tech Systems, Inc. to notify any person or organization of such revisions or changes.

### Trademarks and Registered Trademarks

MultiTech, and the MultiTech logo, MultiConnect, and Dragonfly are trademarks or registered trademarks of Multi-Tech Systems, Inc. All other products and technologies are the trademarks or registered trademarks of their respective holders.

### Legal Notices

The MultiTech products are not designed, manufactured or intended for use, and should not be used, or sold or re-sold for use, in connection with applications requiring fail-safe performance or in applications where the failure of the products would reasonably be expected to result in personal injury or death, significant property damage, or serious physical or environmental damage. Examples of such use include life support machines or other life preserving medical devices or systems, air traffic control or aircraft navigation or communications systems, control equipment for nuclear facilities, or missile, nuclear, biological or chemical weapons or other military applications (“Restricted Applications”). Use of the products in such Restricted Applications is at the user’s sole risk and liability.

MULTITECH DOES NOT WARRANT THAT THE TRANSMISSION OF DATA BY A PRODUCT OVER A CELLULAR COMMUNICATIONS NETWORK WILL BE UNINTERRUPTED, TIMELY, SECURE OR ERROR FREE, NOR DOES MULTITECH WARRANT ANY CONNECTION OR ACCESSIBILITY TO ANY CELLULAR COMMUNICATIONS NETWORK. MULTITECH WILL HAVE NO LIABILITY FOR ANY LOSSES, DAMAGES, OBLIGATIONS, PENALTIES, DEFICIENCIES, LIABILITIES, COSTS OR EXPENSES (INCLUDING WITHOUT LIMITATION REASONABLE ATTORNEYS FEES) RELATED TO TEMPORARY INABILITY TO ACCESS A CELLULAR COMMUNICATIONS NETWORK USING THE PRODUCTS.

The MultiTech products and the final application of the MultiTech products should be thoroughly tested to ensure the functionality of the MultiTech products as used in the final application. The designer, manufacturer and reseller has the sole responsibility of ensuring that any end user product into which the MultiTech product is integrated operates as intended and meets its requirements or the requirements of its direct or indirect customers. MultiTech has no responsibility whatsoever for the integration, configuration, testing, validation, verification, installation, upgrade, support or maintenance of such end user product, or for any liabilities, damages, costs or expenses associated therewith, except to the extent agreed upon in a signed written document. To the extent MultiTech provides any comments or suggested changes related to the application of its products, such comments or suggested changes is performed only as a courtesy and without any representation or warranty whatsoever.

### Contacting MultiTech

#### Knowledge Base

The Knowledge Base provides immediate access to support information and resolutions for all MultiTech products. Visit <http://www.multitech.com/kb.go>.

#### Support Portal

To create an account and submit a support case directly to our technical support team, visit: <https://support.multitech.com>.

#### Support

Business Hours: M-F, 8am to 5pm CT

Country	By Email	By Phone
Europe, Middle East, Africa:	<a href="mailto:support@multitech.co.uk">support@multitech.co.uk</a>	+(44) 118 959 7774
U.S., Canada, all others:	<a href="mailto:support@multitech.com">support@multitech.com</a>	(800) 972-2439 or (763) 717-5863

#### Warranty

To read the warranty statement for your product, visit <https://www.multitech.com/legal/warranty>. For other warranty options, visit [www.multitech.com/es.go](http://www.multitech.com/es.go).

#### World Headquarters

Multi-Tech Systems, Inc.  
 2205 Woodale Drive, Mounds View, MN 55112  
 Phone: (800) 328-9717 or (763) 785-3500  
 Fax (763) 785-9874

# Contents

<b>Chapter 1 – Product Overview .....</b>	<b>6</b>
Overview .....	6
Documentation Overview .....	6
Product Build Options .....	6
MTQ-L4G1-B02 Mechanical Drawing .....	7
Descriptions of LEDs .....	8
<b>Chapter 2 – Hardware and Specifications .....</b>	<b>9</b>
MTQ-L4G1-B02 Specifications .....	9
40-Pin Connector Definitions .....	10
MTQ-L4G1-B02 .....	11
40-Pin Connector .....	12
Electrical Characteristics .....	12
Operating Conditions .....	12
Absolute Maximum Rating .....	12
DC Electrical Characteristics .....	13
Input/Output Current Ratings .....	13
Power Draw - MTQ-L4G1-B02 .....	14
<b>Chapter 3 – Getting Started .....</b>	<b>15</b>
Installing a SIM Card on a DragonFly .....	15
Device Drivers .....	15
USB Cable Recommendations .....	15
Communications Flow .....	16
No Processor Model (B02) .....	16
Communicating with the Device .....	16
Powering Down The Device .....	16
Device Reset (Pin 35) .....	17
Low Power Options .....	17
<b>Chapter 4 – Antennas .....</b>	<b>18</b>
External Antenna Option .....	18
Antenna .....	18
SMA to U.FL Cables .....	19
Connecting an Antenna through the Developer Board Connectors .....	19
Antenna Diversity .....	20
Placing External Antennas .....	20
Selecting Antennas .....	20
Antenna Approvals and Safety Considerations .....	21
Diversity and Power Draw .....	21

<b>Chapter 5 – Safety Information .....</b>	<b>22</b>
Handling Precautions .....	22
Radio Frequency (RF) Safety .....	22
Sécurité relative aux appareils à radiofréquence (RF).....	22
General Safety.....	23
Interference with Pacemakers and Other Medical Devices .....	23
Potential interference .....	23
Precautions for pacemaker wearers .....	23
Vehicle Safety.....	23
Device Maintenance .....	24
User Responsibility.....	24
<b>Chapter 6 – Labels.....</b>	<b>25</b>
Labels .....	25
<b>Chapter 7 – Regulatory Information.....</b>	<b>26</b>
47 CFR Part 15 Regulation Class B Devices .....	26
FCC Interference Notice .....	26
FCC Grant Information .....	26
Industry Canada Class B Notice.....	28
Canadian Limitations.....	29
Industry Canada .....	30
EMC, Safety, and Radio Equipment Directive (RED) Compliance .....	32
Regulatory Compliance Mark (RCM) for Australia.....	32
<b>Chapter 8 – Environmental Notices.....</b>	<b>33</b>
Waste Electrical and Electronic Equipment Statement .....	33
WEEE Directive.....	33
Instructions for Disposal of WEEE by Users in the European Union .....	33
REACH Statement .....	33
Registration of Substances.....	33
Restriction of the Use of Hazardous Substances (RoHS) .....	34
<b>Chapter 9 – Using Connection Manager .....</b>	<b>35</b>
Installing Connection Manager .....	35
Setting Up a Serial Device in Windows Device Manager.....	36
Connecting a Device.....	38
Uninstalling Connection Manager.....	39
Connection Manager User Interface.....	40
Main tab.....	40
Settings tab .....	41
Connection tab.....	41
Details tab .....	41
Terminal tab.....	41
Charts tab.....	41

---

Troubleshooting .....	42
Serial COM port is not available in the Serial Modem Settings.....	42
Device is not detected ("No Device") .....	42
MultiConnect Cell USB Modem is not detected .....	42
Connection Manager is not working, and a device connected to the computer is not detected.....	42
Connection Manager displays "Device Error" status for a serial device .....	42
<b>Index.....</b>	<b>43</b>

# Chapter 1 – Product Overview

## Overview

The Dragonfly™ (MTQ) embedded cellular modem is fully certified and MNO approved. These ready-to-integrate modules offer an onboard cellular radio in a compact design.

## Documentation Overview

The following documents are available at <https://www.multitech.com/brands/multiconnect-dragonfly>. Select your model to find the documents specific for that device.

Document	Description	Part Number
Dragonfly MTQ-L4G1 Device Guide	Hardware, regulatory, and getting started information.	S000762
Universal Developer Kit 2.0 Developer Guide	Provides information on using the developer board with the MTQ.	S000610
Quectel EG25x AT Commands Manual, USB Driver Installation Guides, and other related manuals	Multiple documents listing AT Commands, USB Driver Installation Guides (both Windows and Linux), and other protocols used to communicate with your L4G1 device. Provided in a zip file.	N/A

## Product Build Options

Product	Description	Region
MTQ-L4G1-B02	Embedded LTE Cat 4 Modem with Fallback and GNSS (50 Pk)	NA, EU, and AU
MTQ-L4G1-B02-SP	Embedded LTE Cat 4 Modem with Fallback and GNSS (1 Pk)	NA, EU, and AU

### Note:

These units ship without network activation. To connect them to the cellular network, you need SIM cards from your service provider.

The complete product code may end in .Rx. For example, MTQ-L4G1-B02.Rx, where R is revision and x is the revision number.

All builds can be ordered individually or in 50-packs.

# MTQ-L4G1-B02 Mechanical Drawing

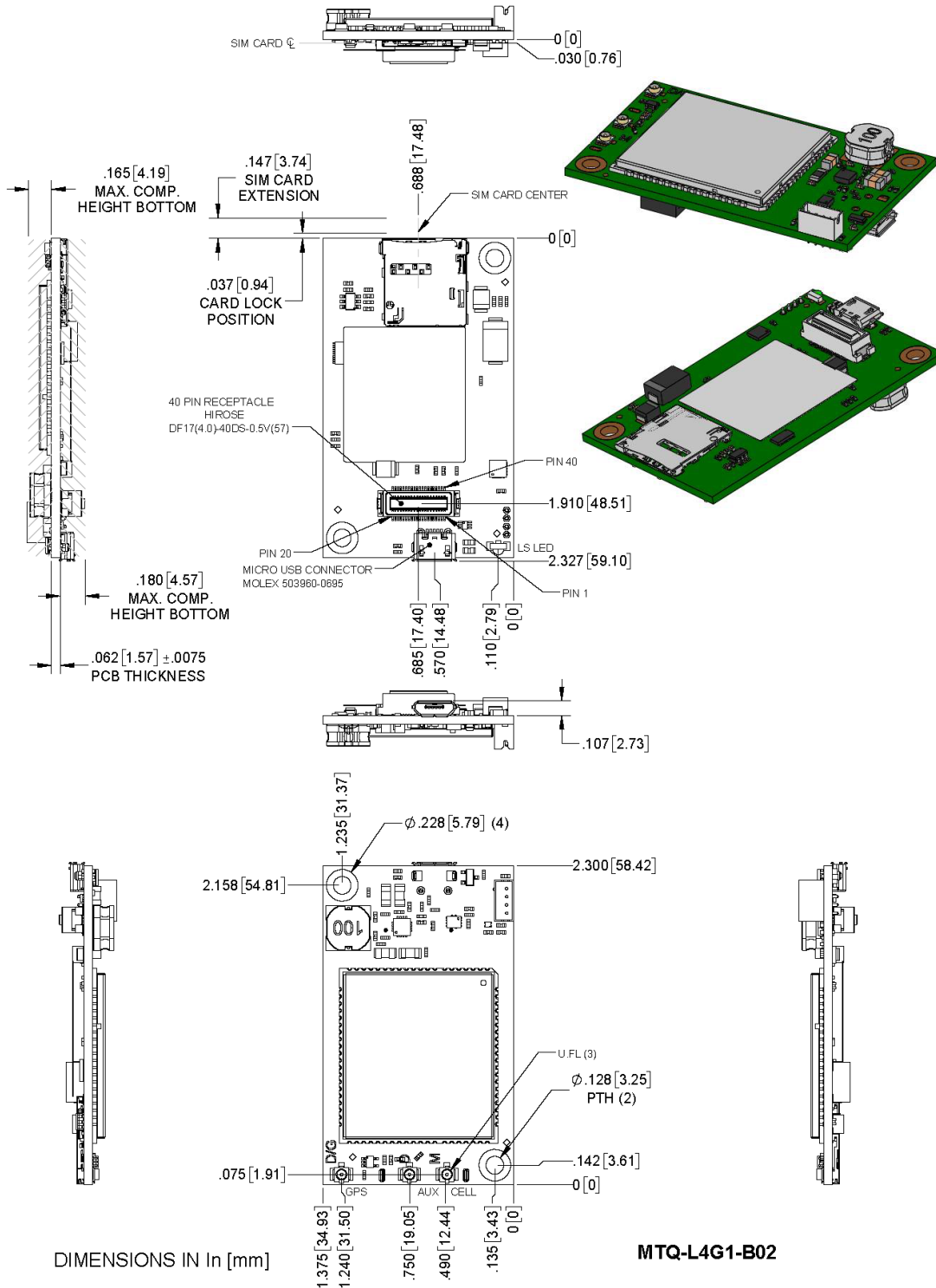

## Descriptions of LEDs

The Link Status LED is located on the SIM side of the device to the right of the Micro USB Connector in the lower right corner.

LED Indicators	
LS	<p>Link Status</p> <ul style="list-style-type: none"><li>■ OFF —No power to the cellular radio</li><li>■ Slow Blink (200 ms High/1800 ms Low) — Not registered/searching for network connection</li><li>■ Slow Blink (1800 ms High/200 ms Low) — Idle</li><li>■ Fast Blink (125 ms High/125 ms Low) — Connected/data transfer</li></ul>



## Chapter 2 – Hardware and Specifications

### MTQ-L4G1-B02 Specifications

Category	Description
<b>General</b>	
Standards	3GPP Rel. 11 LTE
	4G LTE FDD/TDD
	UMTS/HSPA+
	GSM/GPRS/EDGE
	USB Interface is CDC-ACM compliant
TCP/IP Functions	FTP, SMTP, SSL, TCP, UDP
Frequency Bands	LTE FDD: B1/B2/B3/B4/B5/B7/B8/B12/B13/B18/B19/B20/B25/B26/B28
	LTE TDD: B38/B39/B40/B41
	WCDMA: B1/B2/B4/B5/B6/B8/B19
	GSM: B2/B3/B5/B8
<b>Speed</b>	
Data Speed	LTE FDD: Max 150Mbps (DL)/Max 50Mbps (UL)
	LTE TDD: Max 130Mbps (DL)/Max 35Mbps (UL)
	UMTS: DC-HSDPA: Max 42Mbps (DL)
	UMTS: HSUPA: Max 5.76Mbps (UL)
	UMTS: WCDMA: Max 384Kbps (DL)/Max 384Kbps (UL)
	GSM: EDGE: Max 296Kbps (DL)/Max 236.8Kbps (UL)
	GSM: GPRS: Max 107Kbps (DL)/Max 85.6Kbps (UL)
<b>Interface</b>	
USB Interface	Micro USB 2.0 high speed
UART	Full UART
Serial Modem Interface	Up to 921.6 Kbps
<b>Physical Description</b>	
Weight	0.6 oz (17g)
Dimensions	Refer to Mechanical Drawings for details.
<b>Connectors</b>	
Antenna	3 surface mount U.FL: GPS, Cellular, Diversity
SIM Holder	1.8 V and 3 V micro
Pin header	40-pin female for USB or UART

Category	Description
<b>Environment</b>	
Operating Temperature	-40° C to +85° C
Storage Temperature	-40° C to +85° C
Humidity	20%-90% RH, non-condensing

Category	Description
<b>Power Requirements</b>	
Operating Voltage	3.3 - 5 V +/- 5%
Input Current	See Power Draw
<b>Certifications and Compliance</b>	
EMC and Radio Compliance	FCC Part 15 Class B
	FCC Part 22H
	FCC Part 24E
	FCC Part 27
	CE Mark, RED (EU)
	RCM (AU)
Safety Compliance	UL 60950-1 2nd Edition
	cUL 60950-1 2nd Edition Am. 1 and Am. 2
	IEC60950-1(EU)
Telecom Approvals	Verizon, AT&T, PTCRB

- Radio performance may be affected by temperature extremes.
- Device has been tested up to +85° C. UL Recognized@ 85° C

## 40-Pin Connector Definitions

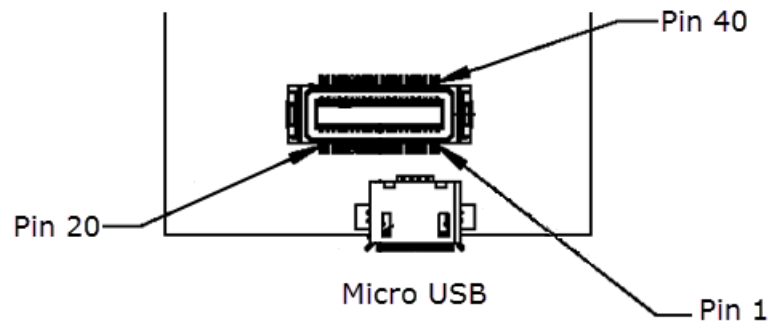

**MTQ-L4G1-B02**

Pin	Signal Name	Logic Level Voltage <sup>1</sup>	Max Voltage	In/Out	Description
1	N/C				
2	N/C				
3	N/C				
4	N/C				
5	GND	GND		GND	Ground
6	USB-DATA+	0 - 3V <sup>2</sup>	5.5V	I/O	USB Data
7	USB-DATA-				
8	VCC-IN	3.3 - 5V +/-5%		Power Input	Main Power
9	RADIO_RXD	0 - 3V	3.3V	O	Serial data output to DTE
10	RADIO_DCD	0 - 3V	3.3V	O	Data carrier detect
11	RADIO_RI	0 - 3V	3.3V	O	Ring indicator
12	RADIO_CTS	0 - 3V	3.3V	O	Clear to send (flow control)
13	GND	GND		GND	Ground
14	N/C				
15	N/C				
16	N/C				
17	N/C				
18	N/C				
19	N/C				
20	N/C				
21	N/C				
22	N/C				
23	N/C				
24	N/C				
25	N/C				
26	N/C				
27	RADIO_VDD	0-1.8V	1.8V	O	This output is generated by the radio.
28	GND	GND		GND	Ground
29	RADIO_RTS	0 - 3.3V	3.3V	I	Request to send (flow control)
30	RADIO_DSR	0 - 3V	3.3V	O	Data set ready
31	RADIO_DTR	0 - 3.3V	3.3V	I	DTE ready

Pin	Signal Name	Logic Level Voltage <sup>1</sup>	Max Voltage	In/Out	Description
32	RADIO_TXD	0 - 3.3V	3.3V	I	Serial data input from DTE
33	VCC-IN	3.3 - 5V +/-5%		Power Input	Main Power
34	LINK_STATUS	3V		O	Radio link status LED
35	RESET	0 - 1.8V		I	Radio reset, treat as open drain, active low
36	GND	GND		GND	Ground
37	GND				
38	N/C				
39	N/C				
40	N/C				

<sup>1</sup>A hyphen (-) indicates a range of acceptable logic levels.

<sup>2</sup>USB D+D-: 5V tolerant inputs / 3V drive-level output

## 40-Pin Connector

Manufacturer: Hirose Electric Co LTD  
 Description: .5MM 40 PN B>B RECEPTACLE  
 Model Number: DF17(4.0)-40DP-0.5V(57)

Use with:

Manufacturer: Hirose Electric Co LTD  
 Description: .5mm 40 pin B.B header MALE  
 Model Number: DF17(2.0)-40DP-0.5V(57)

## Electrical Characteristics

### Operating Conditions

Parameter	Minimum Volts	Maximum Volts
Supply Range - Vcc	3.3V +/-5%	5V +/-5%

### Absolute Maximum Rating

Parameter	Minimum Volts	Maximum Volts
Voltage at any signal pin	-0.3	5.5

## DC Electrical Characteristics

Parameter	Conditions	Minimum Volts	Maximum Volts
Digital signal input low level	CMOS port $I_{IO}=+8$ mA	-0.3	0.9
Digital signal input high level	CMOS port $I_{IO}=+8$ mA	2.1	5.5
Output low level voltage for an I/O pin	CMOS port $I_{IO}=+8$ mA	-	0.4
Output high level voltage for an I/O pin		$V_{DD}-0.4$	-
Output low level voltage for an I/O pin	TTL port $I_{IO}=+8$ mA	-	0.4
Output high level voltage for an I/O pin		2.4	-
Output low level voltage for an I/O pin	$I_{IO}=+20$ mA	-	1.3 <sup>(1)</sup>
Output high level voltage for an I/O pin		$V_{DD}-1.3$ <sup>(1)</sup>	-
Output low level voltage for an I/O pin	$I_{IO}=+6$ mA	-	0.4 <sup>(1)</sup>
Output high level voltage for an I/O pin		$V_{DD}-0.4$ <sup>(1)</sup>	-
Output low level voltage for an I/O pin	$I_{IO}=+4$ mA	-	0.4 <sup>(2)</sup>
Output high level voltage for an I/O pin		$V_{DD}-0.4$ <sup>(2)</sup>	-
RESET (low active) input low	CMOS port $I_{IO}=+8$ mA	-	0.99
RESET (low active) input high	CMOS port $I_{IO}=+8$ mA	1.8	-

(1) Guaranteed by characterization results, not tested in production.

(2) Guaranteed by design, not tested in production.

## Input/Output Current Ratings

Output current draw PWR_GOOD, CHG_MON	5 mA
Output current draw all other output pins	25 mA

## Power Draw - MTQ-L4G1-B02

Radio Protocol	Power Down Mode via AT+QPOWD (mA)	Power Down Mode via Reset line (uA)	Live Connection Idle - No Data (mA)	Callbox Connection Idle - No Data (mA)	Average Measured Current at Max Power (mA) <sup>1</sup>	TX Pulse <sup>2</sup> AVG Amplitude Current for Peak Current for HSDPA/LTE (mA)	Total Inrush Charge <sup>3</sup> Measured in Millicoulombs (mC)
<b>5 Volts WITH Unit in developer card</b>							
GSM850	9.2	561	25	27	289	1,310	2.06
WCDMA Band 2 (1854 Mhz)	9.2	561	22	26	459	548	2.06
LTE Band 8 (897.5 Mhz)	9.3	562	27	48	539	632	2.06

<sup>1</sup>**Maximum Power:** The continuous current during maximum data rate with the radio transmitter at maximum power.

<sup>2</sup>**Tx Pulse:** The average peak current during a GSM850 transmission burst period or HSDPA/LTE connection. The transmission burst duration for GSM850 can vary, depending on what transmission scheme is being deployed (GPRS Class 8, Class 10, GSM, etc.).

<sup>3</sup>**Inrush Charge:** The total inrush charge at power on.

## Chapter 3 – Getting Started

### Installing a SIM Card on a DragonFly

**Note:** When using the Dragonfly with a developer board, install the SIM card before mounting the Dragonfly on the developer board.

To install the SIM card:

- With the contact side facing down, align the notched edge as shown on the Dragonfly's SIM holder and slide the SIM card completely into the SIM holder.

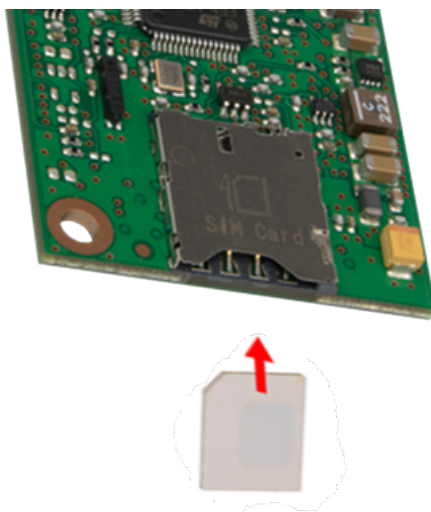

### Device Drivers

**Note:** Install drivers on your computer before connecting the device.

For driver installation instructions for Quectel radios using Windows, refer to the Windows USB Drivers Installation Guide (see **Documentation** in Chapter 1 for more details).

For driver installation instructions for Quectel radios using Linux, refer to the Linux USB Driver User Guide (see **Documentation** in Chapter 1 for more details).

### USB Cable Recommendations

To avoid enumeration or power issues if your device has a USB connector:

- Use a high-speed USB cable that is as short as possible.
- Use a well-shielded cable with at least 24 AWG wire pair for power/ground and 28 AWG wire pair for data lines.
- If possible, use a USB port that connects directly to the motherboard rather than a USB port with added cabling inside the computer chassis.
- Use USB 3.0 ports if available. These ports are typically rated for more current.
- You can order the USB cable through MultiTech. The part number is CA-USB-A-MICRO-B-3.

## Communications Flow

### No Processor Model (B02)

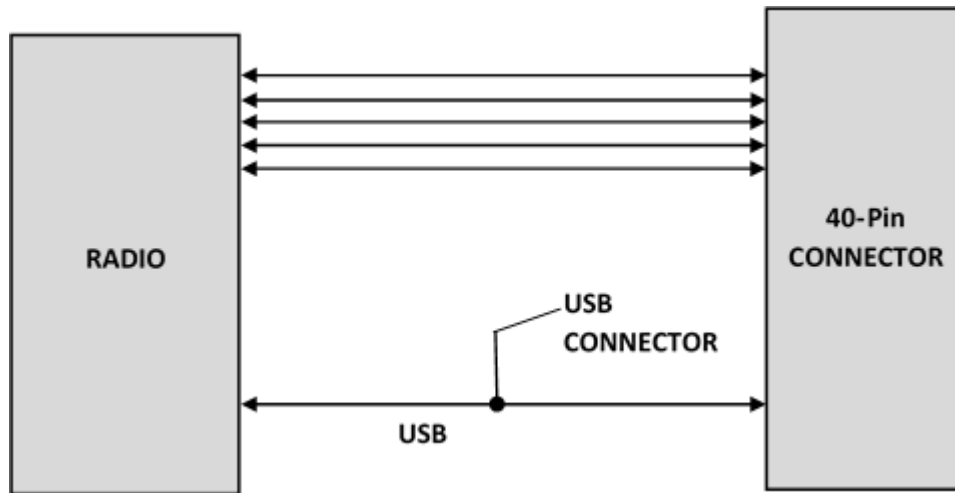

**Note:**

- Simultaneous serial and USB communication are allowed on this device.

## Communicating with the Device

Following are three options for communicating with the device.

- Install USB drivers and plug into the micro USB connector. No need for a host board.
- Access the device's USB interface via pins 6 and 7 of the 40-pin connector. Data pins 6 and 7 are in parallel with the micro USB connector on the device. There is no connection to pins 6 and 7 on the developer board.
- Establish serial communication using Multitech developer board MTUDK2. See the *Universal Developer Kit 2.0 Developer Guide* (PN S000610) for more information.

Following are three options for communicating with the device.

- Install cellular radio USB drivers and plug into the micro USB connector. No need for a host board.
- Establish serial communication using MultiTech developer board MTUDK2. See the *Universal Developer Kit 2.0 Developer Guide* (PN S000610) for more information.
- Install cellular radio USB drivers. Access the device's USB interface via pins 6 and 7 of the 40-pin connector. Data pins 6 and 7 are in parallel with the micro USB connector on the device. There is no connection to pins 6 and 7 on the developer board.

## Powering Down The Device

**CAUTION:** Failing to properly power down the device before removing power may corrupt your device's file system.

To properly power down your device, use the following sequence:

1. Issue the AT+QPOWD command or hold the reset line (pin 35) low.
2. Wait up to 65 seconds for POWERED DOWN message or until RADIO\_VDD (pin 27) goes low.
3. Remove power to the MTQ.



## Device Reset (Pin 35)

Minimum pulse is 50 ms.

- - If the reset line is held low for >50ms the radio is turned off.
- - When the reset line is released, the radio is turned on.

## Low Power Options

See **Powering Down the Device** for the lowest power consumption.

- Refer to AT+QSCLK in the **AT Command Reference Guide** for details on sleep mode and other options.

## Chapter 4 – Antennas

### External Antenna Option

#### Antenna

Devices were approved with the following antenna:

Manufacturer:	Wieson
Description:	LTE Antenna with SMA-Male Connector
Model Number	GY115IE002-001

#### MultiTech ordering information:

Model	Quantity
ANLTE4-1HRA	1
ANLTE4-2HRA	2
ANLTE4-10HRA	10
ANLTE4-50HRA	50

#### Antenna Specifications

Category	Description
Frequency Range	0.698 - 0.96 GHz 1.710 - 2.170 GHz 2.30 - 2.69 GHz
VSWR	3:1 maximum
Gain	2.06 dBi
Impedance	50Ω nominal
Radiation	Omni-directional
Polarization	Linear, vertical

## SMA to U.FL Cables

The developer kit includes three 4.5" SMA to U.FL cables which are preinstalled on the developer board. Consult the mechanical drawings for your device to determine which antenna to connect to which U.FL connector on the device.



## Connecting an Antenna through the Developer Board Connectors

To connect an antenna to the device through the developer board:

1. Determine which SMA connector you want to use for the antenna.
2. Finger tighten the antenna to the SMA connector.
3. Attach the U.FL connector from the cable to the connector on the device.

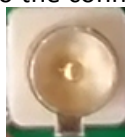

D = Diversity

G = GPS

M = Main

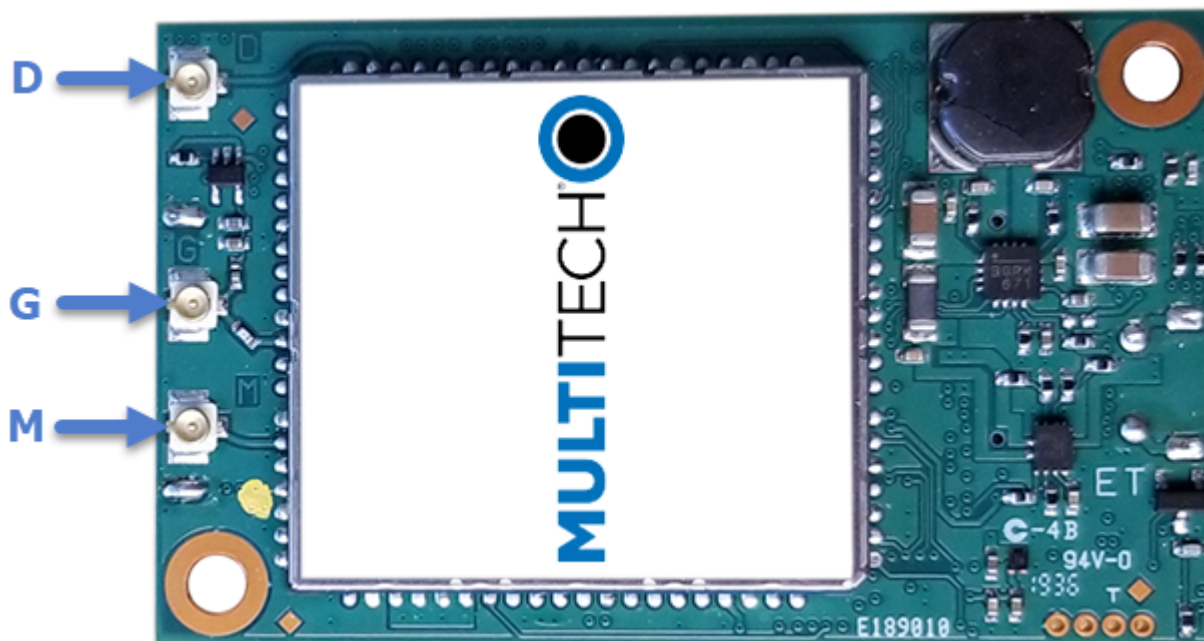

## Antenna Diversity

Antenna diversity uses two receive antennas to improve the downlink connection (cell tower to mobile). It has no effect on the uplink (mobile to cell tower).

Antenna diversity is useful in environments where the signal arrives at the device after bouncing off or around buildings or other objects. The bounced signal may be attenuated by going through semi-transparent (to the signal) objects. Each signal alteration can change its magnitude, phase, orientation, or polarization. This complex environment can exist in cities, inside buildings or in traffic. In this environment, signal paths from the cell tower form an interference pattern of peaks and nulls. These peaks and nulls can be very close together.

Antenna diversity provides an advantage in complex environments because if one receive antenna has a poor signal due to an interference null pattern, the other antenna is likely not in the null and has better reception. The radio compares the reception from both receive antennas and uses the one with the strongest signal.

## Placing External Antennas

Antennas are usually a quarter wavelength apart from each other. With multiband radios where the quarter wavelengths in each band are diverse from each other, this rule may not be practical. Choose spacing based on the band used most often or the band with connection difficulty. Some environments are harsher on particular bands. Multi-Tech products have antenna connectors at the best spacing for the product size.

Placing antennas in close proximity to each other is not optimal, but you can do it if necessary. It depends on the signal strength to and from each antenna.

## Selecting Antennas

Select an antenna based on your product and application. Typically, both antennas are the same because either can be the main receive antenna. However, if the antenna connectors are too close together, use a similar antenna on a short cable for the second receive only antenna.

## Antenna Approvals and Safety Considerations

Note the following:

- The carriers conduct antenna diversity tests.
- There are no EMC concerns about antenna diversity.
- All antennas need to have a minimum flammability rating.
- Safety requirements depend on your final product.
- Antennas are not approved for outdoor use. Do not extend antennas outside of any building.

## Diversity and Power Draw

There are no significant power draw differences.

**Important:** You must deploy with two antennas, unless your carrier has authorized you to deploy with one antenna.

## Chapter 5 – Safety Information

---

### Handling Precautions

To avoid damage due to the accumulation of static charge use proper precautions, such as an ESD strap, when handling any cellular device to avoid exposure to electronic discharge during handling and mounting the device.

### Radio Frequency (RF) Safety

Due to the possibility of radio frequency (RF) interference, it is important that you follow any special regulations regarding the use of radio equipment. Follow the safety advice given below.

- Operating your device close to other electronic equipment may cause interference if the equipment is inadequately protected. Observe any warning signs and manufacturers' recommendations.
- Different industries and businesses restrict the use of cellular devices. Respect restrictions on the use of radio equipment in fuel depots, chemical plants, or where blasting operations are in process. Follow restrictions for any environment where you operate the device.
- Do not place the antenna outdoors.
- Switch OFF your wireless device when in an aircraft. Using portable electronic devices in an aircraft may endanger aircraft operation, disrupt the cellular network, and is illegal. Failing to observe this restriction may lead to suspension or denial of cellular services to the offender, legal action, or both.
- Switch OFF your wireless device when around gasoline or diesel-fuel pumps and before filling your vehicle with fuel.
- Switch OFF your wireless device in hospitals and any other place where medical equipment may be in use.

### Sécurité relative aux appareils à radiofréquence (RF)

À cause du risque d'interférences de radiofréquence (RF), il est important de respecter toutes les réglementations spéciales relatives aux équipements radio. Suivez les conseils de sécurité ci-dessous.

- Utiliser l'appareil à proximité d'autres équipements électroniques peut causer des interférences si les équipements ne sont pas bien protégés. Respectez tous les panneaux d'avertissement et les recommandations du fabricant.
- Certains secteurs industriels et certaines entreprises limitent l'utilisation des appareils cellulaires. Respectez ces restrictions relatives aux équipements radio dans les dépôts de carburant, dans les usines de produits chimiques, ou dans les zones où des dynamitages sont en cours. Suivez les restrictions relatives à chaque type d'environnement où vous utiliserez l'appareil.
- Ne placez pas l'antenne en extérieur.
- Éteignez votre appareil sans fil dans les avions. L'utilisation d'appareils électroniques portables en avion est illégale: elle peut fortement perturber le fonctionnement de l'appareil et désactiver le réseau cellulaires. S'il ne respecte pas cette consigne, le responsable peut voir son accès aux services cellulaires suspendu ou interdit, peut être poursuivi en justice, ou les deux.
- Éteignez votre appareil sans fil à proximité des pompes à essence ou de diesel avant de remplir le réservoir de votre véhicule de carburant.
- Éteignez votre appareil sans fil dans les hôpitaux ou dans toutes les zones où des appareils médicaux sont susceptibles d'être utilisés.

## General Safety

The device is designed for and intended to be used in fixed and mobile applications. Fixed means the device is physically secured at one location and cannot be easily moved to another location. Mobile means the device is used in other than fixed locations.

**CAUTION:** Maintain a separation distance of at least 20 cm (8 inches) between the transmitter's antenna and the body of the user or nearby persons. The device is not designed for or intended to be used in portable applications within 20 cm (8 inches) of the user's body.

**Attention:** Maintenir une distance d'au moins 20 cm (8 po) entre l'antenne du récepteur et le corps de l'utilisateur ou à proximité de personnes. Le modem n'est pas conçu pour, ou destinés à être utilisés dans les applications portables, moins de 20 cm du corps de l'utilisateur.

## Interference with Pacemakers and Other Medical Devices

### Potential interference

Radio frequency energy (RF) from cellular devices can interact with some electronic devices. This is electromagnetic interference (EMI). The FDA helped develop a detailed test method to measure EMI of implanted cardiac pacemakers and defibrillators from cellular devices. This test method is part of the Association for the Advancement of Medical Instrumentation (AAMI) standard. This standard allows manufacturers to ensure that cardiac pacemakers and defibrillators are safe from cellular device EMI.

The FDA continues to monitor cellular devices for interactions with other medical devices. If harmful interference occurs, the FDA will assess the interference and work to resolve the problem.

### Precautions for pacemaker wearers

If EMI occurs, it could affect a pacemaker in one of three ways:

- Stop the pacemaker from delivering the stimulating pulses that regulate the heart's rhythm.
- Cause the pacemaker to deliver the pulses irregularly.
- Cause the pacemaker to ignore the heart's own rhythm and deliver pulses at a fixed rate.

Based on current research, cellular devices do not pose a significant health problem for most pacemaker wearers. However, people with pacemakers may want to take simple precautions to be sure that their device doesn't cause a problem.

- Keep the device on the opposite side of the body from the pacemaker to add extra distance between the pacemaker and the device.
- Avoid placing a turned-on device next to the pacemaker (for example, don't carry the device in a shirt or jacket pocket directly over the pacemaker).

## Vehicle Safety

When using your device in a vehicle:

- Do not use this device while driving.
- Respect national regulations on the use of cellular devices in vehicles.
- If incorrectly installed in a vehicle, operating the wireless device could interfere with the vehicle's electronics. To avoid such problems, use qualified personnel to install the device. The installer should verify the vehicle electronics are protected from interference.

- Using an alert device to operate a vehicle's lights or horn is not permitted on public roads.
- UL evaluated this device for use in ordinary locations only. UL did NOT evaluate this device for installation in a vehicle or other outdoor locations. UL Certification does not apply or extend to use in vehicles or outdoor applications.

## Device Maintenance

Do not attempt to disassemble the device. There are no user serviceable parts inside.

When maintaining your device:

- Do not misuse the device. Follow instructions on proper operation and only use as intended. Misuse could make the device inoperable, damage the device and/or other equipment, or harm users.
- Do not apply excessive pressure or place unnecessary weight on the device. This could result in damage to the device or harm to users.
- Do not use this device in explosive or hazardous environments unless the model is specifically approved for such use. The device may cause sparks. Sparks in explosive areas could cause explosion or fire and may result in property damage, severe injury, and/or death.
- Do not expose your device to any extreme environment where the temperature or humidity is high. Such exposure could result in damage to the device or fire. Refer to the device specifications regarding recommended operating temperature and humidity.
- Do not expose the device to water, rain, or spilled beverages. It is not waterproof. Exposure to liquids could result in damage to the device.
- Do not place the device alongside computer discs, credit or travel cards, or other magnetic media. The information contained on discs or cards may be affected by the device.
- Using accessories, such as antennas, that MultiTech has not authorized or that are not compliant with MultiTech's accessory specifications may invalidate the warranty.

If the device is not working properly, contact MultiTech Technical Support.

## User Responsibility

Respect all local regulations for operating your wireless device. Use the security features to block unauthorized use and theft.



# Chapter 6 – Labels

## Labels

This device is an industry and/or carrier approved modem. In most cases, when integrated and used with an antenna system that was part of the MultiTech modem certification, additional approvals or certifications are not required for the device that you develop as long as the following requirement is met:

- Model Identification:** The MultiTech model identification allows the carrier to verify the modem as one of its approved models. This information is located on the modem's label below the bar code.

### Labels

This device complies with the RED directive (EU). Operation is subject to the following two conditions: (1) This device may not cause harmful interference, and (2) this device must accept any interference received, including interference that may cause undesired operation.

- 1 - MultiTech Model Identification
- 2 - MultiTech Ordering Part Number
- 3 - IMEI (not available on Package Label)

Device Label	Package Label
 <p>1 → Model: MTQ-L4G1-B02</p> <p>2 → ORDER P/N: MTQ-L4G1-B02 SKU #: 94558230LF DOM: 2020.06.10 Serial#: xxxxxxxx FCC ID: XMR201903EQ25G IC: 10224A-201903EQ25G</p> <p>3 → IMEI: xxxxxxxxxxxxxxxx</p> <p>FOR EVALUATION ONLY, NOT FCC APPROVED FOR RESALE</p> <p>Produced in the US of US and non-US components www.multitech.com</p>	 <p>SKU (TP) 94558230LF</p> <p>FOR EVALUATION ONLY, NOT FCC APPROVED FOR RESALE.</p> <p>1 → MODEL: MTQ-L4G1-B02</p> <p>2 → ORDER P/N: MTQ-L4G1-B02</p> <p>MultiTech Dragonfly™ Embedded Modem</p> <p>Embedded LTE Cat 4 Cellular Modem w/GNSS 3.3-5V, 50 Pk - Global</p> <p>QTY:(Q) 50</p>

## Chapter 7 – Regulatory Information

### 47 CFR Part 15 Regulation Class B Devices

This equipment has been tested and found to comply with the limits for a Class B digital device, pursuant to part 15 of the FCC Rules. These limits are designed to provide reasonable protection against harmful interference in a residential installation. This equipment generates, uses, and can radiate radio frequency energy and, if not installed and used in accordance with the instructions, may cause harmful interference to radio communications. However, there is no guarantee that interference will not occur in a particular installation. If this equipment does cause harmful interference to radio or television reception, which can be determined by turning the equipment off and on, the user is encouraged to try to correct the interference by one or more of the following measures:

- Reorient or relocate the receiving antenna.
- Increase the separation between the equipment and receiver.
- Connect the equipment into an outlet on a circuit different from that to which the receiver is connected.
- Consult the dealer or an experienced radio/TV technician for help.

**Warning:** Changes or modifications to this unit not expressly approved by the party responsible for compliance could void the user's authority to operate the equipment.

#### FCC Interference Notice

This device complies with part 15 of the FCC Rules. Operation is subject to the following two conditions:

1. This device may not cause harmful interference, and
2. This device must accept any interference received, including interference that may cause undesired operation.

#### FCC Grant Information

<b>FCC Identifier:</b>	XMR201903EG25G
<b>Equipment Class:</b>	PCS Licensed Transmitter
<b>Notes:</b>	LTE Module
<b>Modular Type:</b>	Single Modular
<b>FCC Rule Parts:</b>	22H, 24E, 27, 90

Rule Parts	Frequency Range	Output Watts	Frequency Tolerance	Emission Designator
22H	824.2 - 848.8	1.8493	0.1 PPM	247KGXW
22H	824.2 - 848.8	0.4797	0.1 PPM	245KG7W
24E	1850.2 - 1909.8	1.3335	0.1 PPM	249KGXW
24E	1850.2 - 1909.8	0.6012	0.1 PPM	249KG7W
24E	1852.4 - 1907.6	0.3524	0.1 PPM	4M15F9W
27	1712.4 - 1752.6	0.3819	0.1 PPM	4M14F9W
22H	826.4 - 846.6	0.2512	0.1 PPM	4M13F9W

Rule Parts	Frequency Range	Output Watts	Frequency Tolerance	Emission Designator
24E	1860.0 - 1900.0	0.4198	0.1 PPM	17M9G7D
24E	1860.0 - 1900.0	0.2259	0.1 PPM	17M9W7D
24E	1850.7 - 1909.3	0.2547	0.1 PPM	1M09W7D
27	1720.0 - 1745.0	0.4887	0.1 PPM	17M9G7D
27	1720.0 - 1745.0	0.2612	0.1 PPM	17M9W7D
27	1710.7 - 1754.3	0.2877	0.1 PPM	1M09W7D
22H	829.0 - 844.0	0.2333	0.1 PPM	8M93G7D
22H	829.0 - 844.0	0.1703	0.1 PPM	8M93W7D
22H	825.5 - 847.5	0.235	0.1 PPM	2M70G7D
22H	824.7 - 848.3	0.1936	0.1 PPM	1M09W7D
27	2510.0 - 2560.0	0.4864	0.1 PPM	17M9G7D
27	2510.0 - 2560.0	0.3177	0.1 PPM	17M9W7D
27	2502.5 - 2567.5	0.3192	0.1 PPM	4M49W7D
27	704.0 - 711.0	0.3475	0.1 PPM	8M93G7D
27	704.0 - 711.0	0.2183	0.1 PPM	8M93W7D
27	699.7 - 715.3	0.2472	0.1 PPM	1M09W7D
27	782.0 - 782.0	0.4217	0.1 PPM	8M91G7D
27	782.0 - 782.0	0.2911	0.1 PPM	8M91W7D
27	779.5 - 784.5	0.4395	0.1 PPM	4M48G7D
27	779.5 - 784.5	0.309	0.1 PPM	4M49W7D
24E	1860.0 - 1905.0	0.3516	0.1 PPM	17M9G7D
24E	1860.0 - 1905.0	0.2489	0.1 PPM	17M9W7D
24E	1855.0 - 1910.0	0.4111	0.1 PPM	8M91G7D
24E	1850.7 - 1914.3	0.2429	0.1 PPM	1M09W7D
90	819.0 - 819.0	0.2198	0.1 PPM	8M91G7D
90	819.0 - 819.0	0.1738	0.1 PPM	8M91W7D
90	814.7 - 823.3	0.2455	0.1 PPM	1M09G7D
90	814.7 - 823.3	0.1972	0.1 PPM	1M09W7D
22H	831.5 - 841.5	0.2582	0.1 PPM	13M5G7D
22H	831.5 - 841.5	0.1828	0.1 PPM	13M4W7D
22H	826.5 - 846.5	0.1945	0.1 PPM	4M49W7D
27	2580.0 - 2610.0	0.3926	0.1 PPM	17M8G7D
27	2580.0 - 2610.0	0.2799	0.1 PPM	17M8W7D

Rule Parts	Frequency Range	Output Watts	Frequency Tolerance	Emission Designator
27	2575.0 - 2615.0	0.3936	0.1 PPM	8M91G7D
27	2506.0 - 2680.0	0.4842	0.1 PPM	17M9G7D
27	2506.0 - 2680.0	0.342	0.1 PPM	17M9W7D
27	2501.0 - 2685.0	0.4853	0.1 PPM	8M91G7D
27	2498.5 - 2687.5	0.3451	0.1 PPM	4M50W7D

Single Modular Approval. Power listed is ERP for part 22 and part 27 below 1 GHz, EIRP for part 24 and part 27 above 1 GHz. Approval is limited to OEM installation only. Compliance of this device in all final host configurations is the responsibility of the Grantee. This device is to be used only for mobile and fixed applications. OEM integrators must be provided labeling requirements for finished products. This grant is valid only when the device is sold to OEM integrators and the OEM integrators are instructed to ensure that the end user has no manual instructions to remove or install the device. Separate approval is required for all other operating configurations, including portable configurations with respect to 2.1093 and different antenna configurations. The module antenna(s) must be installed to meet the RF exposure compliance separation distance of 20 cm and any additional testing and authorization process as required. Co-location of this module with other transmitters that operate simultaneously are required to be evaluated using the FCC multi-transmitter procedures. The antenna installation and operating configurations of this transmitter, including any applicable source-based time-averaging duty factor, antenna gain, and cable loss must satisfy MPE categorical Exclusion Requirements of Part 2.1091. Users must be provided with instructions and transmitter operating conditions for satisfying RF exposure compliance. RF exposure compliance may need to be addressed at the time of licensing, as required by the responsible FCC bureau(s), including antenna co-location requirements of Part 1.1307(b)(3). This module can only be used with a host antenna circuit trace layout design in strict compliance with the OEM instructions provided. This device supports: LTE of 1.4, 3, 5, 10, 15, and 20MHz bandwidth modes for LTE Band 2, 4 and 25; and LTE of 1.4, 3, 5 and 10MHz bandwidth modes for LTE Band 5,12 and 26 (814-824MHz),LTE of 5, 10, 15 and 20MHz bandwidth modes for LTE Band 7, 38 and 41; LTE of 5 and 10 MHz bandwidth modes for LTE Band 13; LTE of 1.4, 3, 5,10 and 15MHz bandwidth mode for LTE Band 26(824-849MHz).

The allowed maximum antenna gain including cable loss in a mobile-only exposure condition must not exceed: 8dBi in WCDMA Band 2/LTE Band 2/7/25/38/41; 5dBi in WCDMA /LTE Band 4, and 8.6dBi in GSM850;10.19dBi in PCS1900; 9.42dBi in WCDMA Band 5; 9.41dBi in LTE Band 5; 8.7dBi in LTE Band 12; 9.16dBi in LTE Band 13; 9.36dBi in LTE Band 26(814-824); 9.41dBi in LTE Band 26(824-849).

This device contains functions that are not operational in U.S. Territories. This filing is only applicable for U.S. operations.

## Industry Canada Class B Notice

This Class B digital apparatus meets all requirements of the Canadian Interference-Causing Equipment Regulations.

Cet appareil numérique de la classe B respecte toutes les exigences du Règlement Canadien sur le matériel brouilleur.

This device complies with Industry Canada license-exempt RSS standard(s). The operation is permitted for the following two conditions:

1. the device may not cause interference, and
2. this device must accept any interference, including interference that may cause undesired operation of the device.

Le présent appareil est conforme aux CNR d'Industrie Canada applicables aux appareils radio exempts de licence. L'exploitation est autorisée aux deux conditions suivantes:

1. l'appareil ne doit pas produire de brouillage, et
2. l'appareil doit accepter tout brouillage radioélectrique subi, même si le brouillage est susceptible d'en compromettre le fonctionnement.

## Canadian Limitations

**Notice:** This equipment meets the applicable Industry Canada Terminal Equipment Technical Specifications. This is confirmed by the registration number. The abbreviation, IC, before the registration number signifies that registration was performed based on a Declaration of Conformity indicating that Industry Canada technical specifications were met. It does not imply that Industry Canada approved the equipment.

**Notice:** The REN assigned to each terminal equipment provides an indication of the maximum number of terminals allowed to be connected to a telephone interface. The termination on an interface may consist of any combination of devices subject only to the requirement that the sum of the Ringer Equivalence Numbers of all the devices does not exceed five.

## Limitations canadiennes

**Avis:** Cet équipement respecte les spécifications techniques des équipements terminaux d'Industrie Canada. Cette conformité est confirmée par le numéro d'enregistrement. L'abréviation IC précédant le numéro d'enregistrement signifie que l'enregistrement a été effectué conformément à une Déclaration de Conformité indiquant que les spécifications techniques d'Industrie Canada ont été respectées. Ceci n'indique pas que cet équipement a été approuvé par Industrie Canada.

**Avis:** L'IES (indice d'équivalence de la sonnerie) attribué à chaque terminal fournit une indication du nombre maximal de terminaux pouvant être connectés à une interface téléphonique. La terminaison d'une interface peut être constituée de n'importe quelle combinaison d'appareils à la seule condition que la somme des indices d'équivalence de sonnerie de l'ensemble des appareils ne dépasse pas cinq.

## Industry Canada

<b>Certification Number/No. de Certification</b>	10224A-201903EG25G
<b>Type of Radio Equipment/Genre de Matériel</b>	Modular Approval
	Advanced Wireless Services Equipment/Matériel des services sans fil évolués (1710-1780 MHz and 2110-2180 MHz)
	Cellular Mobile GSM/ Téléphone cellulaire mobile GSM (824-849 MHz)
	Broadband Radio Service (2500-2690 MHz)
	Mobile Broadband Service (MBS) Equipment (698-756/777-787 MHz)
	Cellular Mobile New Technologies/Téléphone cellulaire mobile - Nouvelles technologies (824-849 MHz)
	PCS Mobile/Téléphone mobile SCP (1850-1910 MHz)
<b>Model/Modèle</b>	EG25-G

From Frequency/De Fréquences (MHz)	To Frequency/À Fréquences (MHz)	RF Power (W) Minimum	RF Power (W) Maximum	Measured Bandwidth (kHz)	Emmission Designation / Designation D'émission
825.5	847.5	0.137	0.170	2691	W7D
829.0	844.0	0.139	0.170	8931	W7D
824.7	848.3	0.139	0.194	1094	W7D
826.5	846.5	0.145	0.195	4486	W7D
831.5	841.5	0.150	0.183	13427	W7D
829	844	0.175	0.233	8931	G7D
699.7	715.3	0.175	0.247	1091	W7D
704.0	711.0	.178	.218	8931	W7D
1850.7	1909.3	0.180	0.255	1088	W7D
1860.0	1905.0	0.183	0.249	17862	W7D
831.5	841.5	0.186	0.258	13457	G7D
1860	1900	0.187	0.226	17902	W7D
1850.7	1914.3	0.196	0.273	1091	W7D
1855.0	1910.0	0.198	0.411	8911	G7D
1860.0	1905	0.203	0.352	17862	G7D
1720.0	1745	0.208	0.377	17862	W7D
1710.7	1754.3	0.212	0.288	1091	W7D

From Frequency/De Fréquences (MHz)	To Frequency/À Fréquences (MHz)	RF Power (W) Minimum	RF Power (W) Maximum	Measured Bandwidth (kHz)	Emission Designation / Designation D'émission
2580	2610	0.215	0.280	17822	W7D
1860.	1900	0.218	0.420	17902	G7D
704.0	711.0	0.224	0.348	8931	G7D
779.5	784.5	0.230	0.309	4496	W7D
2502.5	2567.5	0.238	0.319	4486	W7D
782.0	782.0	0.244	0.291	8911	W7D
826.4	846.6	0.246	0.251	4130	F9W
2510.0	2560	0.254	0.318	17862	W7D
1720.0	1745.0	0.262	0.489	17862	G7D
2575.0	2615.0	0.273	0.394	8911	G7D
2580.0	2610.0	0.274	0.393	17822	G7D
2510.0	2680	0.278	0.348	17862	W7D
782.0	782.0	0.302	0.422	8911	G7D
779.5	784.5	0.303	0.440	4476	G7D
2510.0	2560.0	0.313	0.486	17862	G7D
1852.4	1907.6	0.343	0.352	4150	F9W
2510.0	2680.0	0.349	0.488	17902	G7D
1712.4	1752.6	0.366	0.382	4140	F9W
824.2	848.8	0.462	0.480	245	G7W
1850.2	1909.8	0.532	0.601	249	G7W
1850.2	1909.8	1.194	1.334	249	GXW
824.2	848.8	1.714	1.849	248	GXW

Certification of equipment means only that the equipment has met the requirements of the above noted specification. License applications, where applicable to use certified equipment, are acted on accordingly by the Industry Canada issuing office and will depend on the existing radio environment, service and location of operation. This certificate is issued on condition that the holder complies and will continue to comply with the requirements and procedures issued by Industry Canada. The equipment for which this certificate is issued shall not be manufactured, imported distributed, leased, offered for sale or sold unless the equipment complies with the applicable technical specifications and procedures issued by Industry Canada.

La certification du matériel signifie seulement que le matériel a satisfait aux exigences de la norme indiquée ci-dessus. Les demandes de licences nécessaires pour l'utilisation du matériel certifié sont traitées en conséquence par le bureau de délivrance d'Industrie Canada et dépendent des conditions radio ambiantes, du service et de l'emplacement d'exploitation. Le présent certificat est délivré à la condition que le titulaire satisfasse et continue de satisfaire aux exigences et aux procédures d'Industrie Canada. Le matériel à l'égard duquel le présent certificat

est délivré ne doit pas être fabriqué, importé, distribué, loué, mis en vente ou vendu à moins d'être conforme aux procédures et aux spécifications techniques applicable publiées par Industrie Canada.

## EMC, Safety, and Radio Equipment Directive (RED) Compliance



The CE mark is affixed to this product to confirm compliance with the following European Community Directives:

Council Directive 2011/65/EU on the restriction of the use of certain hazardous substances in electrical and electronic equipment;

and

Council Directive 2014/53/EU on radio equipment and telecommunications terminal equipment and the mutual recognition of their conformity.

MultiTech declares that this device is in compliance with the essential requirements and other relevant provisions of Directive 2014/53/EU. The declaration of conformity may be requested at <https://www.multitech.com/landing-pages/events/campaigns/promotions/products/certifications/red-certifications>.

## Regulatory Compliance Mark (RCM) for Australia



This product complies with the requirements of the Regulatory Compliance Mark (RCM) for Electrical Regulatory Authorities Council (ERAC), Electrical Equipment Safety System (EESS), and the Australian Communications and Media Authority (ACMA) for Electromagnetic Compatibility (EMC).



## Chapter 8 – Environmental Notices

### Waste Electrical and Electronic Equipment Statement

**Note:** This statement may be used in documentation for your final product applications.

#### WEEE Directive

The WEEE Directive places an obligation on EU-based manufacturers, distributors, retailers, and importers to take-back electronics products at the end of their useful life. A sister directive, ROHS (Restriction of Hazardous Substances) complements the WEEE Directive by banning the presence of specific hazardous substances in the products at the design phase. The WEEE Directive covers all MultiTech products imported into the EU as of August 13, 2005. EU-based manufacturers, distributors, retailers and importers are obliged to finance the costs of recovery from municipal collection points, reuse, and recycling of specified percentages per the WEEE requirements.

#### Instructions for Disposal of WEEE by Users in the European Union

The symbol shown below is on the product or on its packaging, which indicates that this product must not be disposed of with other waste. Instead, it is the user's responsibility to dispose of their waste equipment by handing it over to a designated collection point for the recycling of waste electrical and electronic equipment. The separate collection and recycling of your waste equipment at the time of disposal will help to conserve natural resources and ensure that it is recycled in a manner that protects human health and the environment. For more information about where you can drop off your waste equipment for recycling, please contact your local city office, your household waste disposal service or where you purchased the product.

July, 2005



### REACH Statement

#### Registration of Substances

**Multi-Tech Systems, Inc.** confirms that none of its products or packaging contain any of the Substances of Very High Concern (SVHC) on the REACH Candidate List, in a concentration above the 0.1% by weight allowable limit

The latest **197** substances restricted per the REACH Regulation were **last updated January 2019**. Refer to the following for the most current candidate list of substances: <http://echa.europa.eu/candidate-list-table>.

## Restriction of the Use of Hazardous Substances (RoHS)

**Multi-Tech Systems, Inc.**

### **Certificate of Compliance**

#### **2015/863**

Multi-Tech Systems, Inc. confirms that its embedded products comply with the chemical concentration limitations set forth in the directive 2015/863 of the European Parliament (Restriction of the use of certain Hazardous Substances in electrical and electronic equipment - RoHS 3).

These MultiTech products do not contain the following banned chemicals<sup>1</sup>:

- Lead, [Pb] < 1000 PPM
- Mercury, [Hg] < 100 PPM
- Cadmium, [Cd] < 100 PPM
- Hexavalent Chromium, [Cr+6] < 1000 PPM
- Polybrominated Biphenyl, [PBB] < 1000 PPM
- Polybrominated Diphenyl Ethers, [PBDE] < 1000 PPM
- Bis(2-Ethylhexyl) phthalate (DEHP): < 1000 ppm
- Benzyl butyl phthalate (BBP): < 1000 ppm
- Dibutyl phthalate (DBP): < 1000 ppm
- Diisobutyl phthalate (DIBP): < 1000 ppm

Environmental considerations:

- Moisture Sensitivity Level (MSL) =1
- Maximum Soldering temperature = 260C (in SMT reflow oven)

<sup>1</sup>Lead usage in some components is exempted by the following RoHS annex, therefore higher lead concentration would be found in some modules (>1000 PPM);

- Resistors containing lead in a glass or ceramic matrix compound.

## Chapter 9 – Using Connection Manager

Use Connection Manager to:

- Install the latest device drivers.
- Connect your device to your carrier's network.

**Note:**

- Connection Manager can install drivers and connect your device regardless of your cellular network; however, activation is only supported with Verizon, Aeris, Sprint, and some regional carriers. If you cannot activate your device with Connection Manager, refer to *Account Activation for Cellular Devices*.
- Switch the firmware in your device to a different carrier (if supported by your device).
- Manage cellular connection and automatically reconnect with the keep-alive feature.
- View device details.
- View line charts of signal level and data rates.
- Use a terminal window for communicating with and troubleshooting the device.

### Installing Connection Manager

Connection Manager installs the appropriate drivers for USB devices along with the application. Serial devices do not require drivers.

**Note:** Attempting to plug in the device before the appropriate drivers are installed can cause the connection to fail.

To install Connection Manager and the device drivers:

1. Go to <https://www.multitech.com/support/connection-manager>.
2. Click **Connection Manager**.
3. Open or unzip the **Connection Manager** file and run the installer (.msi file).
4. In the MultiTech Connection Manager Setup Wizard, read the end-user license agreement and check **I accept the terms in the License Agreement**.
5. Click **Next** to have the installer automatically disable the native WWAN AutoConfig service in Windows.

The WWAN AutoConfig service manages mobile broadband connections. Connection Manager requires that this service be disabled.

**Note:** This page appears only on Windows 10.

6. If a MultiTech device is connected to the computer, disconnect it and click **Next**.
7. If you use a USB device, check **Install the modem driver**.

**CAUTION:** Unless you are certain that the drivers for your USB device are already installed on the computer, make sure that you check **Install the modem driver**. Failure to do this will cause the application to incorrectly detect your device or not detect the device at all.

**Note:** Because serial devices do not require drivers, it does not matter if you check or uncheck **Install the modem driver** for a serial device.

8. To specify a folder for Connection Manager, use the default folder or click **Change** to browse to the folder you want to use.
9. Click **Install**.

A separate wizard opens for installing Telit drivers. Some MultiTech devices use embedded modules from Telit Wireless Solutions to provide cellular connectivity; these devices require Telit drivers.

10. Select **Complete** setup type.
11. When the drivers are installed, click **Finish**.
12. In the Setup Wizard, click **Finish**.

**Note:**

- To open Connection Manager after installation, check **Start the MultiTech Connection Manager when the installation is finished**.
- After the drivers are installed, you need to restart your computer if prompted by Windows.

If using a USB device, you can connect the device to the carrier's network with Connection Manager. Refer to [Connecting a Device](#).

If using a serial device, you need to set up the device in Windows Device Manager before connecting the device. Refer to [Setting Up a Serial Device in Windows Device Manager](#).

**Note:** The –L6G1 radio establishes a connection automatically as soon as the device is plugged into a PC with Windows OS. No configuration or connection steps are required with this device.

## Setting Up a Serial Device in Windows Device Manager

To set up the device in Windows Device Manager:

1. Make sure that your desired COM port for the serial device is available.
2. Connect the serial device to the PC.
3. Go to **Control Panel > Device Manager**. Make a note of the COM port number for the connected device (in **COM Ports**).

Example: The COM port is **COM31**.

4. Go to **Action > Add legacy hardware**.

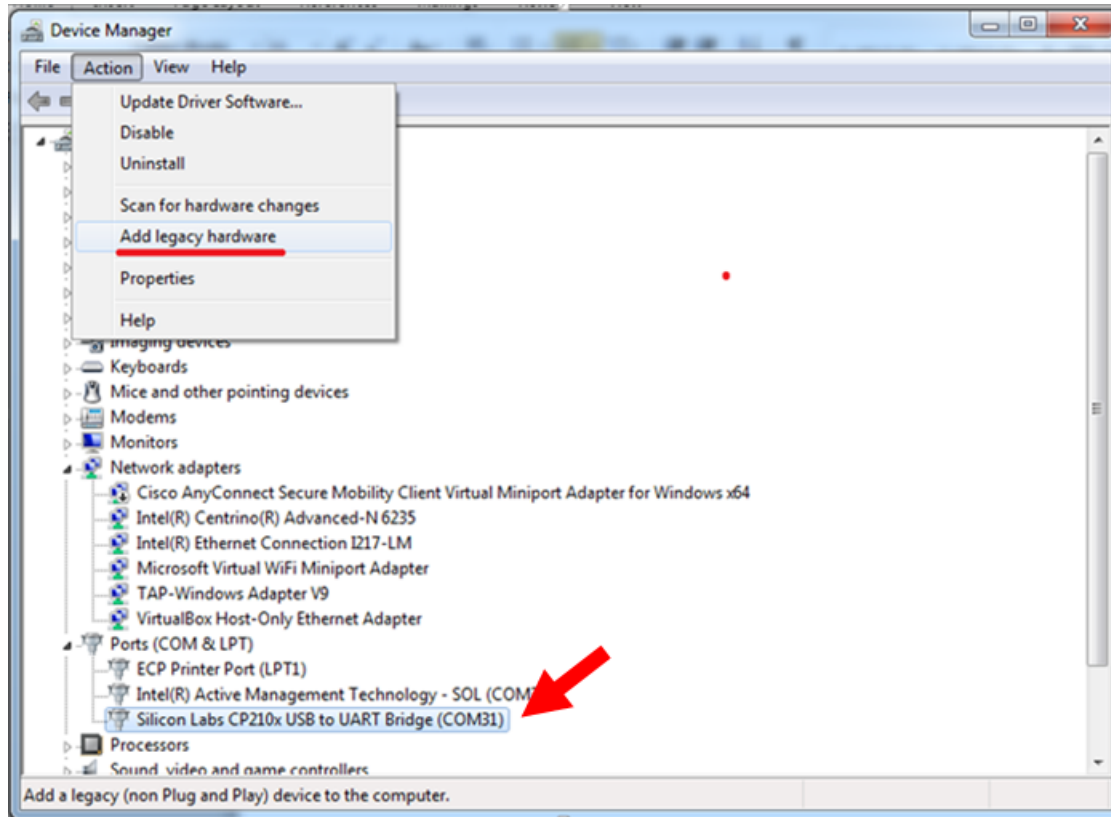

5. In the **Add Hardware Wizard**:

- a. Click **Next**.
- b. Select **Install the hardware that I manually select from a list**, then click **Next**.
- c. Select **Modems**, then click **Next**.
- d. Check **Don't detect my modem; I will select it from a list**, then click **Next**.
- e. Select **Standard Modem Types**, then select **Standard 33600 bps Modem** on the right.

**Important:** Make sure that you select *only* **Standard 33600 bps Modem**. Selecting another model may cause your device to work incorrectly or fail.

- f. Select your COM port, then click **Next**.
- g. Click **Finish**.
- h. Go to **Device Manager > Modems** and confirm that the device is added.

6. To verify that the device is set up correctly, query the device:

- a. Go to **Device Manager > Modems**, right-click **Standard 33600 bps Modem**, and select **Properties**.
- b. On the **Diagnostics** tab, click **Query Modem**.

**Note:** The device cannot be queried if the Connection Manager is running and using the device's port.

If the device is ready, diagnostic information from the device appears in the box above.

To connect the device to your carrier's network, refer to [Connecting a Device](#).

## Connecting a Device

### Before You Begin

- Make sure that your device is connected to the computer where Connection Manager is installed.
- Set up the device in Device Manager. Refer to [Setting Up a Serial Device in Windows Device Manager](#).

**Note:** The –L6G1 radio establishes a connection automatically as soon as the device is plugged into a PC with Windows OS. No configuration or connection steps are required with this device.

To connect your device to the carrier's network:

1. Open Connection Manager.

Connection Manager automatically detects the connected device, and the **Detect** button on the **Main** tab changes to **Connect**. If the application cannot detect the device automatically, click **Detect** to initiate device detection manually.

2. If you are connecting the device to this computer for the first time, on the **Connection** dialog box, provide values for the connection settings, such as the dial number and access point name (APN).

You may need to ask the carrier for these settings.

**Note:** For –L6G1 radios, dial number is disabled.

- a. To monitor Internet connectivity, have Connection Monitor send periodic pings to a host, check **Enable keep-alive** and enter the IP address or host name to ping in the **Host to ping** box. For example, you can enter the host name [google.com](http://google.com) or IP address **8.8.8.8**.

If the keep-alive check fails, Connection Manager automatically reconnects. When the keep-alive feature is enabled, the Connection Manager's **Main** tab displays the keep-alive check status and when the last ping response was received.

- b. If your device supports dual carriers, switch the firmware to the desired carrier by selecting the carrier in the **MNO Firmware** list. For example, if your device can switch the firmware between AT&T and Verizon, select **Verizon** in the list.

**Note:**

- The **MNO Firmware** list doesn't appear if your device doesn't support carrier firmware switching.
- When you change the carrier firmware, the modem automatically restarts to apply the selected firmware.

- c. To save the settings, click **Apply**.

You can change the connection settings on the **Connection** tab. The **Dial number**, **APN**, **User name**, and **Password** cannot be changed after the device is connected.

**Note:** For –L6G1 radios, dial number is disabled.

3. On the **Settings** tab, select **USB Modem** or **Serial Modem** depending on whether you are connecting a USB or serial device.
4. If you are connecting a serial device, provide the serial settings on the **Settings** tab:
  - a. In the **Modem type** list, select the appropriate modem type.

- b. For the other settings, provide the values that match the serial-port settings for the device in Device Manager.

For **Port**, expand **Ports** and notice the COM port number next to the device name. Right-click the device name, select **Properties**, and find the values for the other settings on the **Port Settings** tab.

- c. To save the settings, click **Apply**.

**Note:**

- Settings displayed for a USB device on the **Settings** tab are determined automatically and cannot be changed.
- To set the application to run during Windows startup, check **Run application at Windows startup**.
- To automatically connect to the Internet, check **Connect to the Internet automatically**.

Selecting **Run application at Windows startup** and **Connect to the Internet automatically** is useful in scenarios where Connection Manager is running on a remote computer. If a power failure occurs on the computer, these settings ensure the application will restart and reconnect to the Internet when power is restored.

- 5. On the **Main** tab, click **Connect**.

When a connection is established, the **Main** tab displays the download and upload speeds, the amount of traffic sent and received, **Connected** status, and the signal strength percentage and bars. The statistics on connection speeds and traffic are available only during a current connection session.

**Note:**

- For serial modems, the signal strength is available only when the device is *not* connected to the carrier's network. When connection to the network is established, the last signal strength value is displayed.
- View the details for the current connection on the **Details** tab.

- 6. To disconnect the device from the carrier's network, click **Disconnect**.

## Uninstalling Connection Manager

Along with uninstalling Connection Manager, the installed device drivers are also removed.

### Before You Begin

Make sure that Connection Manager is not running.

To uninstall Connection Manager:

1. In Windows, go to **Control Panel > Programs > Programs and Features**.
2. Right-click **MultiTech Connection Manager** and select **Uninstall**.
3. Click **Yes** to confirm that you want to uninstall Connection Manager.  
The native Windows WWAN AutoConfig service is automatically enabled.
4. When the message "Are you sure you want to uninstall this product?" appears, click **Yes**.

Connection Manager and the installed drivers are removed from the computer.

**Note:** The steps above describe how to uninstall Connection Manager using Control Panel. You can also uninstall the application by using the installer file (.msi). Double-click the file, in the MultiTech Connection Manager Setup Wizard, click **Next**, and then select **Remove** on the next two pages.

## Connection Manager User Interface

Connection Manager consists of the following tabs:

- Main
- Settings
- Connection
- Details
- Terminal
- Charts

MultiTech Connection Manager 1.0.6.77

**MULTITECH**

Main Settings Connector Details Terminal Charts

### Statistics

Download:	0 B/s
Upload:	847 B/s
Sent:	37.39 Kb
Received:	24.39 Kb

Connected

58%

Keep-alive check: **Success**  
Last ping response: 879 ms

Disconnect

### Main tab

The **Main** tab displays the following:

- Status of device connection: Searching, Connecting, Connected, Disconnecting, or Disconnected
- The action button, which changes according to the current device connection status: **Detect**, **Connect**, or **Disconnect**
- Signal strength bars and percentage indicator (only when connection to the carrier's network is established)
  - Note:** The signal strength is displayed for a serial device only when the device is not connected to the carrier's network.



- Connection statistics: download and upload speeds, amount of traffic sent and received (only when connection to the carrier's network is established)
- The keep-alive check status and when the last ping response was received if **Enable keep-alive check** is checked on the **Connection** tab.

## Settings tab

Use the **Settings** tab to specify the type of device: **USB Modem** or **Serial Modem**.

- If **USB Modem** is selected, the tab displays USB settings. These settings cannot be edited.
- If **Serial Modem** is selected, the tab displays the serial settings that match the serial-port settings for the device. You can edit these settings.

The **Settings** tab also contains the **Run application at Windows startup** and **Connect to the Internet automatically** options.

- Check **Run application at Windows startup** to open Connection Manager when Windows starts.
- Check **Connect to the Internet automatically** to set Connection Manager to connect to the carrier's network automatically each time the application opens.

## Connection tab

The **Connection** tab displays the following:

- The carrier-provided connection settings.
- The **Enable keep-alive check** box. Check this box to monitor connectivity to the Internet. Check **Enable keep-alive check** and enter the IP address or host name to ping in the **Host to ping** box. Connection Monitor will send periodic pings to the host. If the keep-alive feature fails, Connection Manager will automatically reconnect.
- The **MNO firmware** list. If your device supports dual carriers, you can switch the firmware to the other carrier by selecting the carrier in this list.

**Note:** The **Connection** tab isn't available if Connection Manager doesn't detect a device.

## Details tab

The **Details** tab displays the modem details when a device is detected and the connection details when a connection is established.

## Terminal tab

The **Terminal** tab contains a terminal window to communicate with the connected device by entering AT commands. For details, refer to the AT Commands reference guide for your device.

**Note:** When a serial device is connected to the carrier's network, the terminal window isn't available.

## Charts tab

The **Charts** tab contains line charts that graphically represent signal strength and download and upload speeds for the 2-hour interval.

## Troubleshooting

### Serial COM port is not available in the Serial Modem Settings

Close Connection Manager and reopen it.

### Device is not detected ("No Device")

After following the steps to activate your device, the **Main** tab still indicates "No Device."

Try the following steps:

1. Click the **Settings** tab and make sure that the appropriate modem type is selected: USB or Serial.
2. If you are connecting a serial device, make sure that all serial modem settings correspond to the serial modem and serial port configuration.
3. Restart Connection Manager.
4. Disconnect and reconnect the device.

### MultiConnect Cell USB Modem is not detected

1. Check the LS LED and Power LED (if available) on the device.  
If the LS LED is not blinking, then the problem is with the power supply. Check the cable and connections.
2. USB device: Make sure that the device is connected to the PC and that the correct USB cable is in use.

### Connection Manager is not working, and a device connected to the computer is not detected

Connection Manager cannot detect a connected device because the required drivers are not installed. The most likely cause is that **Install the modem drivers** was not checked during the installation.

Uninstall and re-install Connection Manager. During the installation, make sure that you check **Install the modem driver**. Refer to [Uninstalling Connection Manager](#) and [Installing Connection Manager](#).

### Connection Manager displays "Device Error" status for a serial device

This error has the following causes and solutions.

Cause	Solution
Connection Manager cannot open the COM port that the device was installed on because the port is being used by another program.	If possible, free up the COM port for the device.
The wrong COM port is specified for the device on the <b>Settings</b> tab.	On the <b>Settings</b> tab, select the COM port that matches the port that the device is installed on and click <b>Apply</b> . You can look up the port in Device Manager in Windows. In Device Manager, expand <b>Modems</b> , right-click the name of your device, and select <b>Properties</b> . Note the port on the <b>Modem</b> tab.

# Index

<b>A</b>	
absolute maximum rating.....	12
activation.....	35
antenna .....	18
connecting .....	19
diversity.....	20
AT#SHDN.....	16
<b>B</b>	
build options .....	6
<b>C</b>	
cable.....	19
certification	
Industry Canada .....	30
Class B .....	26
Industry Canada .....	28
communicating with the device.....	16
Connection Manager	
Charts tab.....	40
connecting device to carrier's network .....	38
Connection tab.....	40
Details tab.....	40
installation .....	35
installation of device drivers.....	35
Main tab.....	40
overview .....	35
Settings tab .....	40
Terminal tab.....	40
troubleshooting .....	42
uninstalling.....	39
<b>D</b>	
device	
connecting to carrier's network with Connection Manager.....	38
maintenance .....	24
device drivers	
installation for use with Connection Manager .....	35
diversity.....	20
documentation.....	6
<b>E</b>	
electrical characteristics.....	12
<b>F</b>	
FCC Notice	
Class B .....	26
<b>H</b>	
hazardous substances .....	34
<b>I</b>	
Industrie Canada .....	29
Industry Canada .....	29 30
Class B .....	28
interférence des radiofréquences.....	22
<b>M</b>	
maintenance .....	24
mechanical drawings.....	7
model location .....	25
modem	
safety .....	23
<b>O</b>	
on off signal.....	17
operating conditions .....	12
<b>P</b>	
pin	
connector definitions.....	10
pin connector .....	12
power down .....	16
power draw	
MTQ-LEU7 .....	14
<b>R</b>	
radio frequency interference.....	22
RoHS.....	34

**S**

safety	
modem.....	23
RF interference .....	22
vehicle.....	23
shutdown .....	16
SIM card, installing.....	15
sleep mode.....	17
SMA to U.FL.....	19
SMA to U.FL cable.....	19
specifications.....	9
static.....	22
sécurité	
interférences RF.....	22

**T**

troubleshooting	
Connection Manager .....	42

**U**

U.FL .....	19
user responsibility.....	24

**V**

vehicle safety .....	23
----------------------	----